

Evaluation of Subsystem Clock Oscillation Circuit

[R5F3640DDFA-100P] QFP(14x20) 0.65mm pitch

Measurement conditions : 3.3V

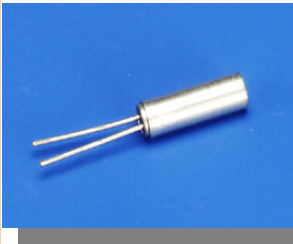

Model :VT-200
 Frequency :Fo=32.768kHz
 Frequency tolerance :dF/Fo= +/-20x10⁻⁶
 Load capacitance :CL=12.5pF
 Equivalent series resistance :R1=50kohm max
 Max. Drive level :DL=1x10⁻⁶W max
 Recommended drive level :DL=0.1x10⁻⁶W typ

FEATURES

- 1.Compact tubular package
- 2.Photolithographic process
- 3.Excellent shock resistance and environmental characteristics.
- 4.Real time clocks, Timers, Portable applications

DIMENSIONS(VT-200)

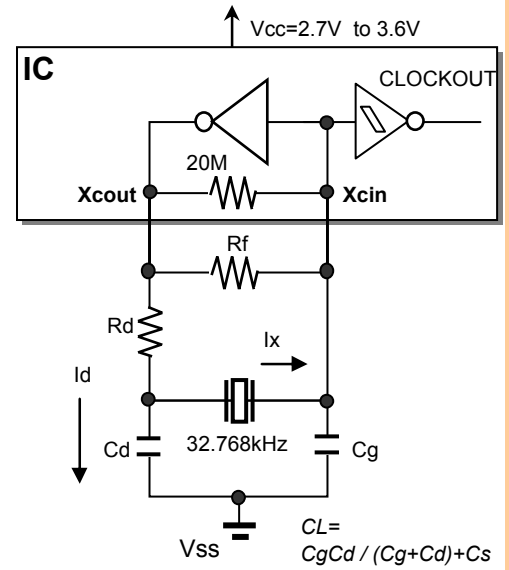
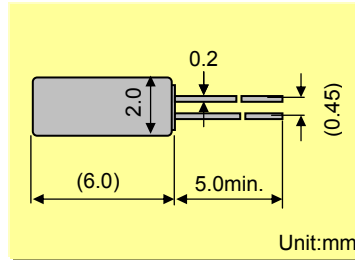

Remark) Ix : current through crystal

*1 ; low consumption current mode

*2 ; high consumption current mode

MODEL:VT-200 12.5pF with R5F3640DDFA at Vcc=3.3V,25°C

Key specifications	Low(*1)	High(*2)	Remarks
Negative feedback resistance : Rf (M ohm)	10	10	Rf*=20*10/(20+10)=6.7Mohm (composition)
Current control resistance : Rd (k ohm)	100	220	Control drive level & secure phase margin
Capacitance at gate : Cg (pF)	18	18	Optimal capacitance in response to CL
Capacitance at drain : Cd (pF)	22	22	(CL = Cd // Cg + stray capacitance)

Circuit characteristics (at 25°C)	Low(*1)	High(*2)	Remarks
Matching Accuracy : df / f (x10 ⁻⁶)	-1.1	4.1	Frequency offset volume at specified Vcc
Voltage Fluctuation : +/-df / V (x10 ⁻⁶)	0.5	0.2	Vcc +/-10% (Standard operating voltage range)
Drive Level : DL (x10 ⁻⁶ W)	0.11	0.15	DL=Ix ² Re < 1x10 ⁻⁶ W, Re=R1(1 + Co / CL) ²
Negative resistance : - RL (kohm)	302	782	5 times larger than R _{1MAX} :
Oscillation allowance : M (times)	6.0	15.6	Judgemental standard of oscillation stability
Consumption current : Id (nA)	1238	1477	Cd charge current, Id = ωCd*Vd
Oscillation start up time : Ts (sec)	0.46	0.30	Time to reach 90% of output level

Temperature characteristics of circuit		Low(*1)	High(*2)	Remarks
at -40°C	Variation : df / T (x10 ⁻⁶)	-139	-139	Typ.Tp=25°C (K = -3.5x10 ⁻⁸ / °C ²)
at +85°C	Variation : df / T (x10 ⁻⁶)	-128	-129	Typ.Tp=25°C (K = -3.5x10 ⁻⁸ / °C ²)

The above mentioned value is only for your reference. The value is for the arbitrary samples and does not guarantee the product's characteristics. Please review and check above parameters at customer's end.

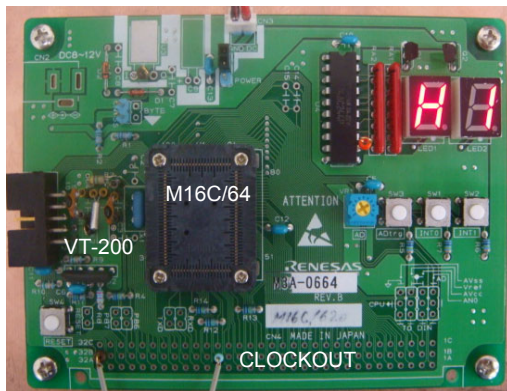

Seiko Instruments USA Inc.

2990,West Lomita Blvd., Torrance, CA 90505, U.S.A
 Telephone :+1 310-517-7771 Facsimile :+1 310-517-7792
 Email :info@siu-la.com

Seiko Instruments GmbH

Siemensstrasse 9,D-63263 Neu-Isenburg,Germany
 Telephone :+49-6102-297-0 Facsimile :+49-6102-297-320
 Email :info@seiko-instruments.de

Seiko Instruments Inc.

1-8,Nakase,Mihama-ku,Chiba-shi,Chiba 261-8507,Japan
 Facsimile :+81-43-211-8030 E-mail :component@sii.co.jp

Seiko Instruments Inc.

Phone:+81-43-211-1207(Direct)



We value the "takumi" spirit.

Evaluation of Subsystem Clock Oscillation Circuit

[R5F3640DDFA-100P] QFP(14x20) 0.65mm pitch
 Measurement conditions : 3.3V



Test Data at 25°C

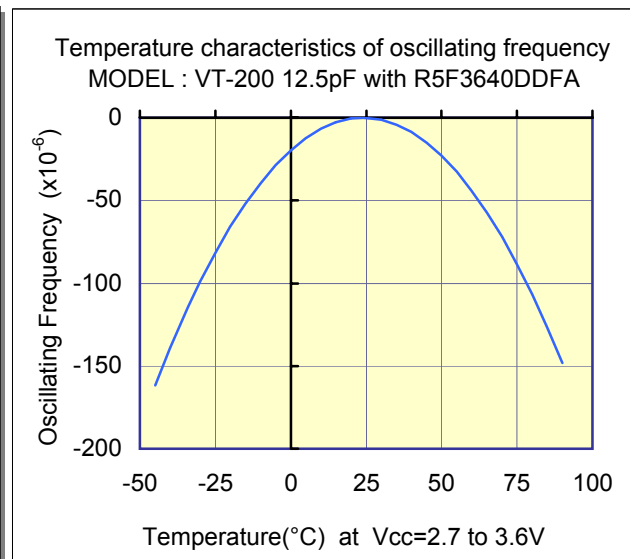
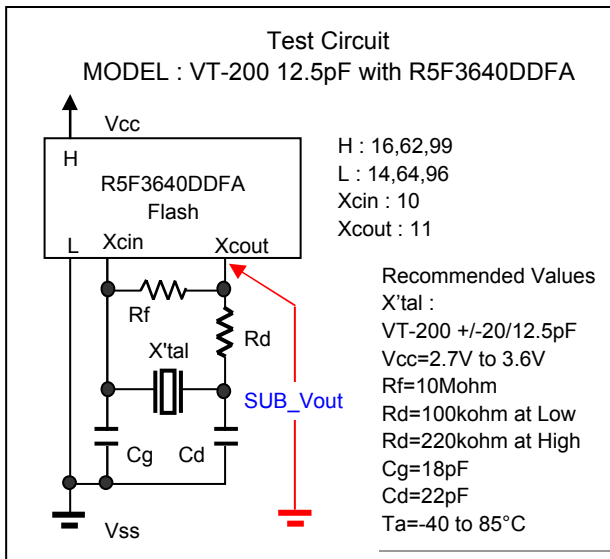
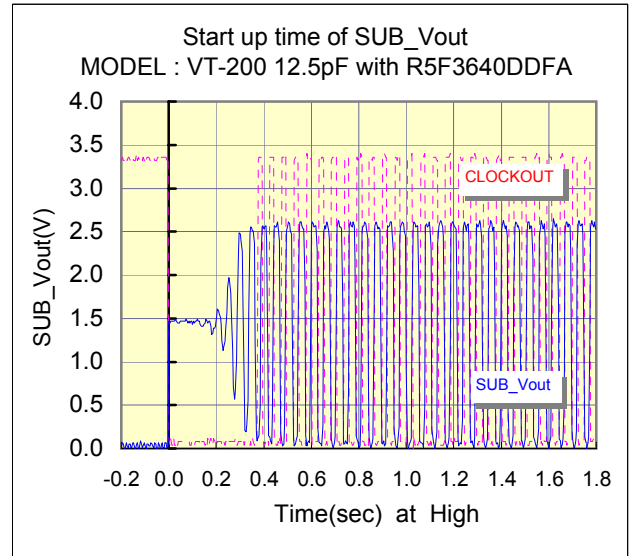
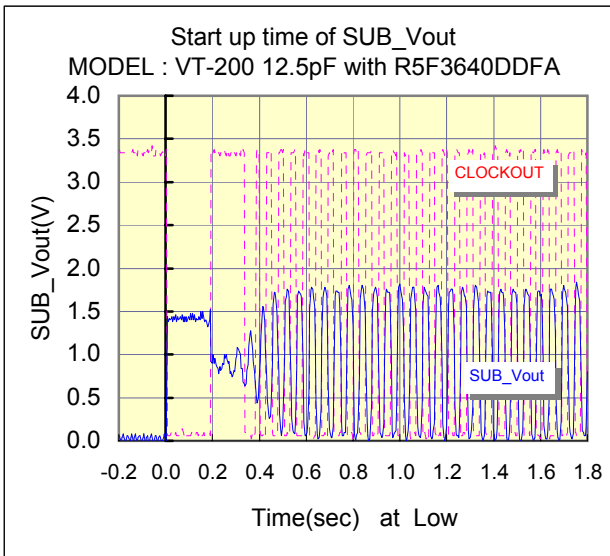
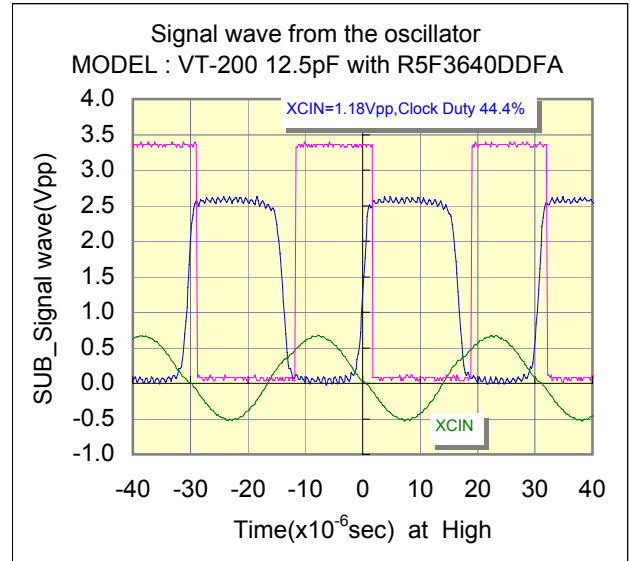
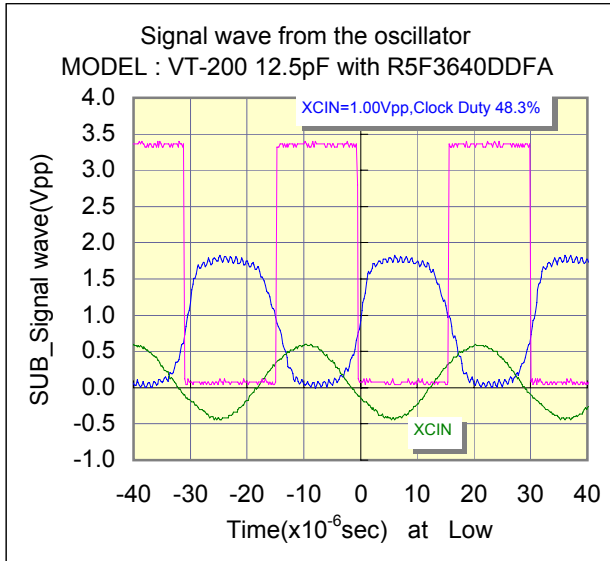

Evaluation of Subsystem Clock Oscillation Circuit

[R5F3640DDFA-100P] QFP(14x20) 0.65mm pitch

Measurement conditions : 3.3V



Test Data : Temperature characteristics

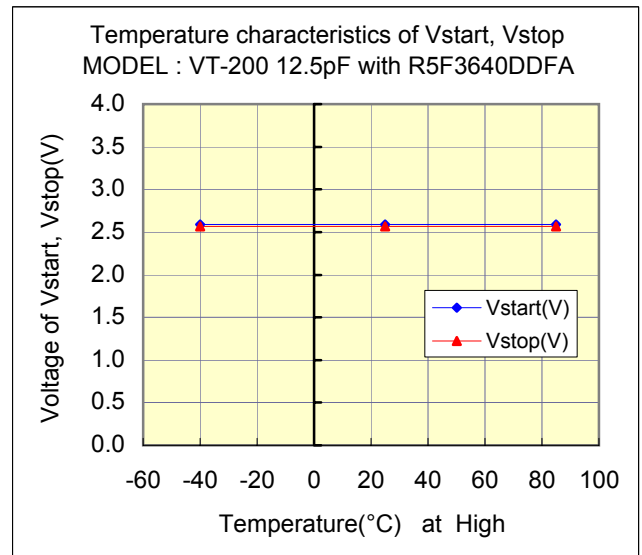
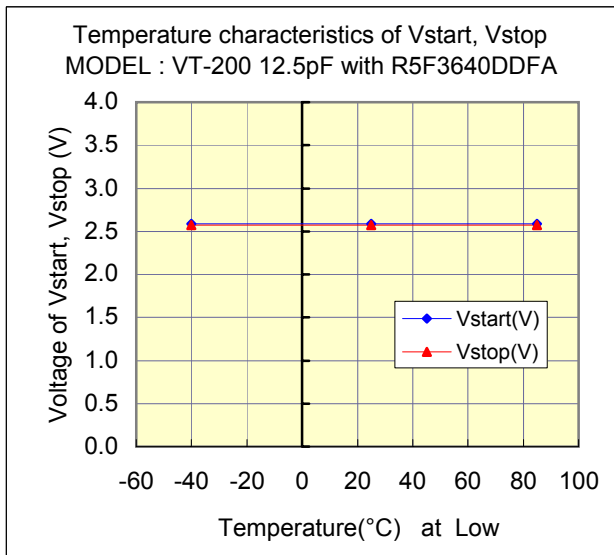
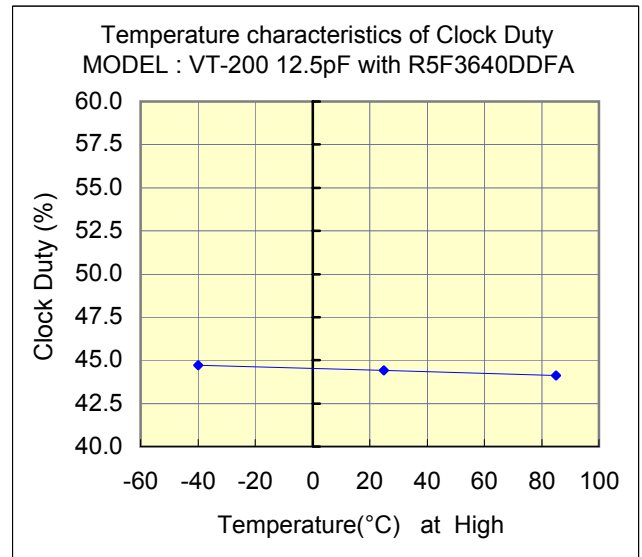
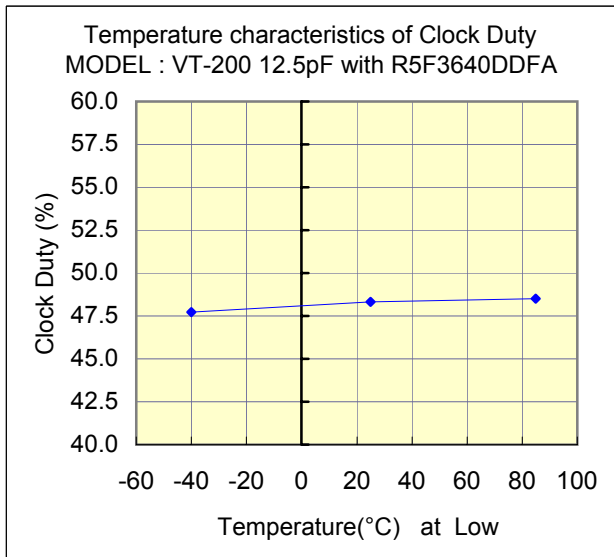
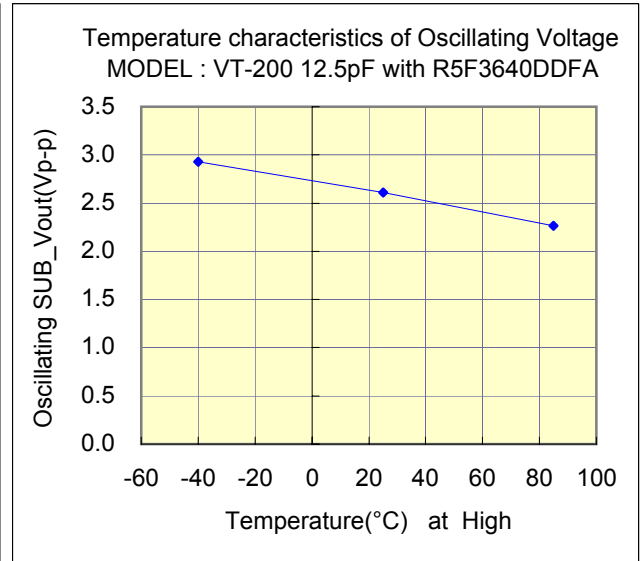
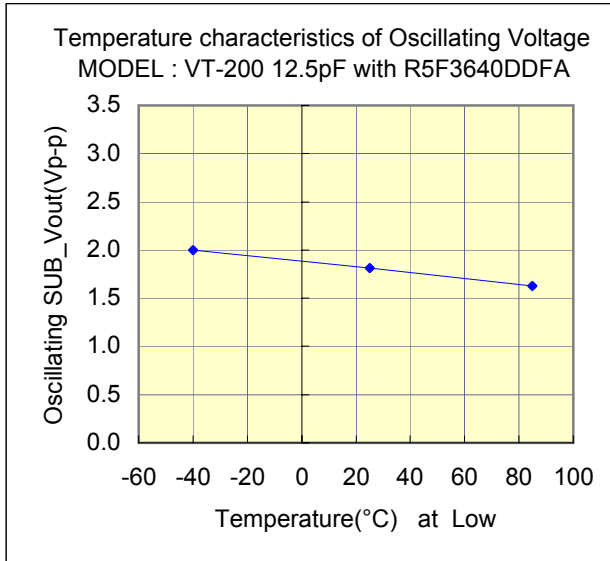

Evaluation of Subsystem Clock Oscillation Circuit

[R5F3640DDFA-100P] QFP(14x20) 0.65mm pitch

Measurement conditions : 3.3V



Referential components layout(see Figure 1)

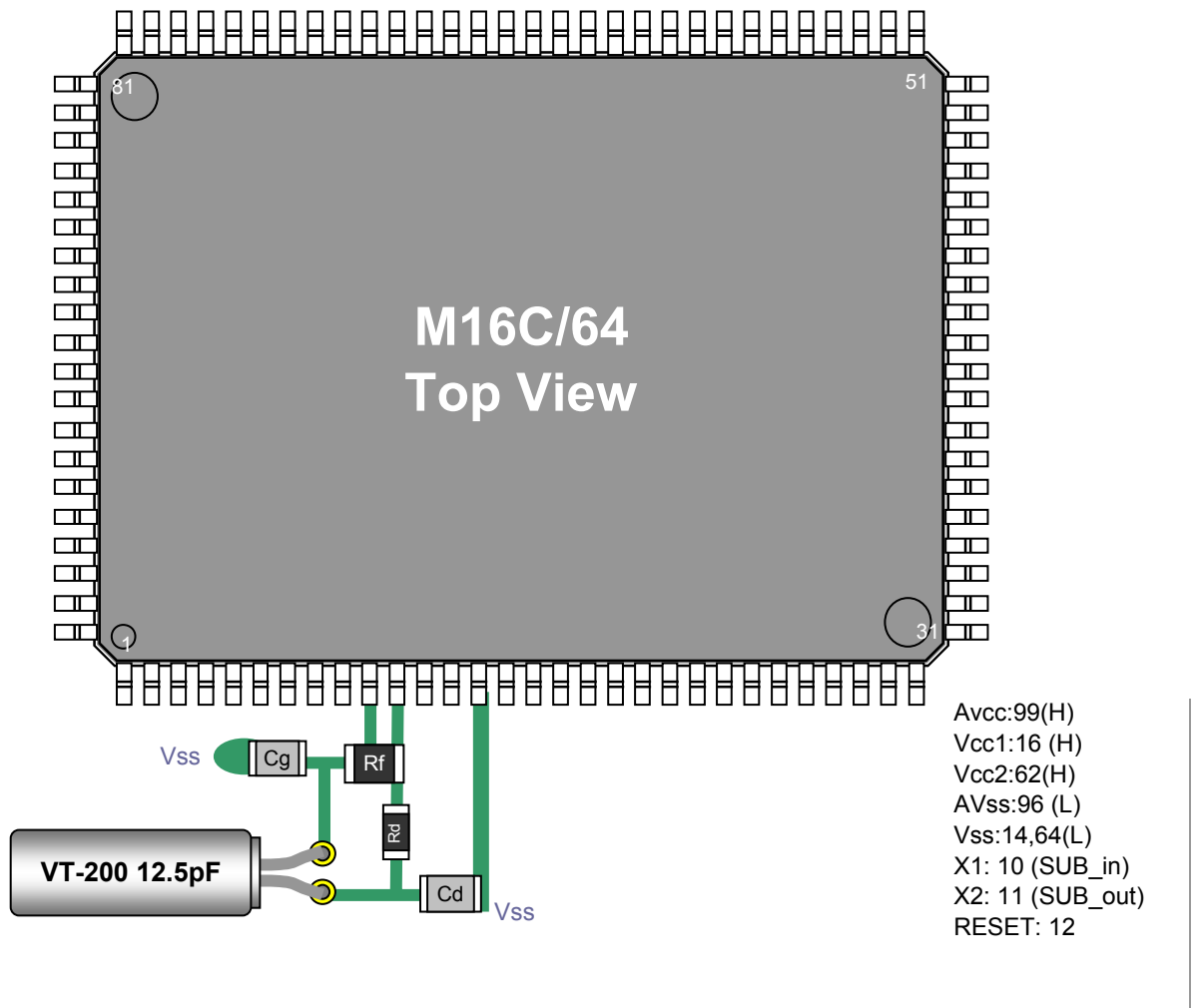

Figure 1 Referential components layout

Notes Board Design

When using a crystal resonator, place the resonator and its load capacitors as close as possible to SUB_in and SUB_out pins.

Other signal lines should be routed away from the resonator circuit to prevent induction from interfering with correct oscillation (see figure 2).

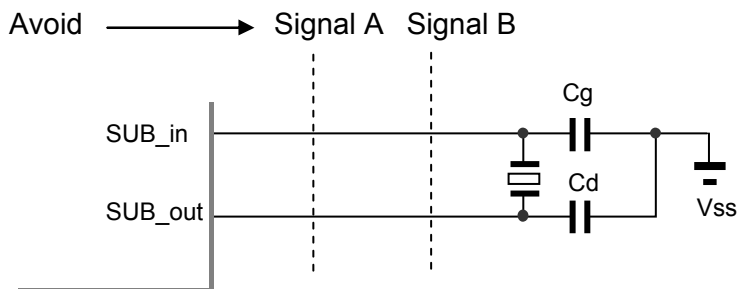

Figure 2 Example of Incorrect Board Design

Remark When using the subsystem clock, insert resistors Rd in series on the SUB_out side.

Evaluation of Subsystem Clock Oscillation Circuit

[R5F3640DDFA-100P] QFP(14x20) 0.65mm pitch

Measurement conditions : 3.3V



[Evaluation Sample : VT-200 12.5pF at 25°C]

SAMPLE	No.	CL(pF)	Fo(Hz)	fr(Hz)	R1(kohm)	Co(pF)	C1(fF)	Q(k)
VT-200 12.5pF	1	12.5	32768.30	32765.60	27.8	0.89	2.207	79.2
	2	12.5	32768.09	32765.24	26.9	0.89	2.333	77.4
	3	12.5	32768.34	32765.45	29.9	0.93	2.368	68.6

[IC Test Data : IC sample Rf=10M0hm,Rd=220kohm,Cg=18pF,Cd=22pF at 25°C]

Mode	IC sample	Fosc(Hz)	df / f(x10 ⁻⁶)	DL(x10 ⁻⁶ W)	-RL (kohm	Vstart(V)	Ts(sec)	XCIN(Vpp)	Id(nA)
High	TYP	32768.44	4.12	0.15	782	2.59	0.30	1.18	1477
	HHD	32768.44	4.36	0.17	782	2.59	0.31	1.25	1563
	LLD	32768.43	3.85	0.12	782	2.59	0.30	1.06	1363

[IC Test Data : IC sample Rf=10Mohm,Rd=100kohm,Cg=18pF,Cd=22pF at 25°C]

Mode	IC sample	Fosc(Hz)	df / f(x10 ⁻⁶)	DL(x10 ⁻⁶ W)	-RL (kohm	Vstart(V)	Ts(sec)	XCIN(Vpp)	Id(nA)
Low	TYP	32768.27	-1.07	0.11	302	2.59	0.46	1.00	1238
	HHD	32768.26	-1.22	0.12	292	2.59	0.46	1.06	1338
	LLD	32768.27	-0.92	0.09	332	2.59	0.45	0.91	1135

Remark (see figure 3)

$$F_o = f_r \times \{ C_1 / (2 \times (C_o + C_L)) + 1 \} \text{ (Hz)}$$

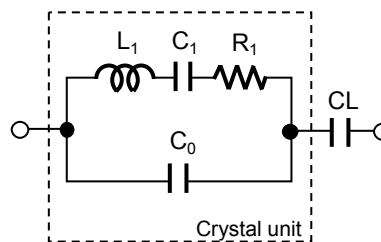

- Fo : Load resonance frequency
- fr : Resonance frequency
- R1 : Motional resistance
- C1 : Motional capacitance
- Co : Shunt capacitance
- CL : Load Capacitance

Figure 3 Equivalent circuit of crystal unit, and CL

Remark (see figure 4)

Approximate formula of the load capacitance of the circuit CL.

$$CL = C_g \times C_d / (C_g + C_d) + C_s \text{ (pF)}$$

$$C_s = C_{os} + C_{gs} \times C_{ds} / (C_{gs} + C_{ds}) \text{ (pF)}$$

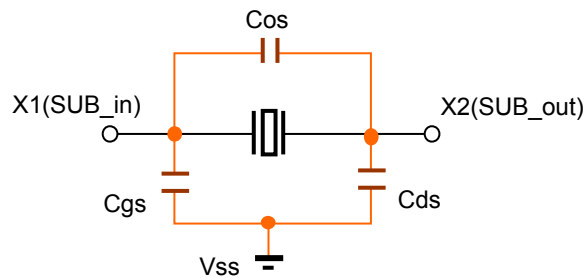

Where Cs(=2 to 4pF) Stands for stray capacitance of the circuit.

- Cos : X1_X2 Stray capacitance
- Cgs : X1_Vss Stray capacitance
- Cds : X2_Vss Stray capacitance

Figure 4 Stray capacitance Cos,Cgs,Cds of the circuit

Resonator circuit constants will differ depending on the resonator element, stray capacitance in its interconnecting circuit, and other factors. Suitable constants should be determined in consultation with the resonator element manufacturer.

Evaluation of Subsystem Clock Oscillation Circuit

[R5F3640DDFA-100P] QFP(14x20) 0.65mm pitch
 Measurement conditions : Vcc=2.7V to 3.6V at 25°C



Referential Data(1) : Voltage characteristics

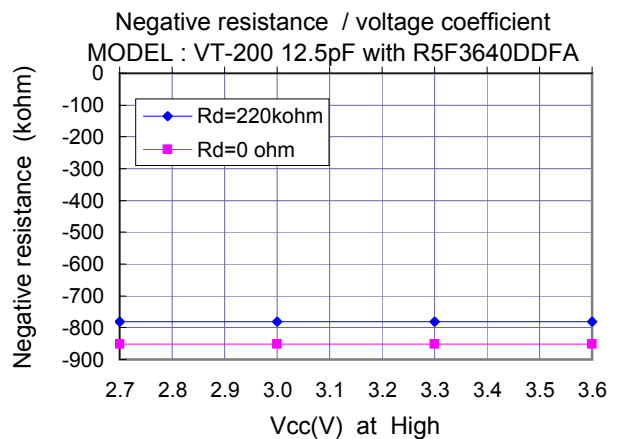
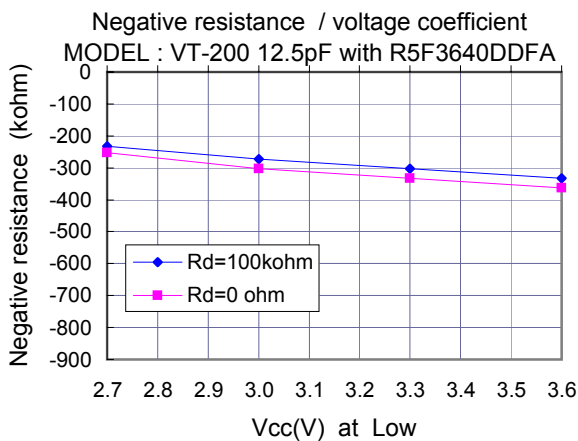
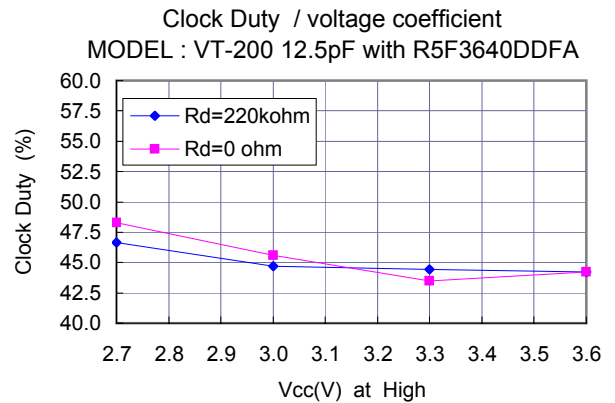
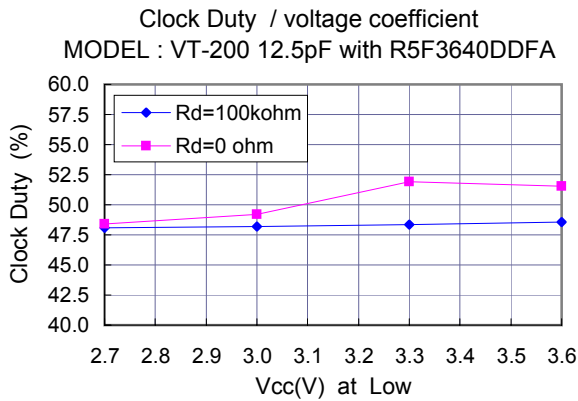
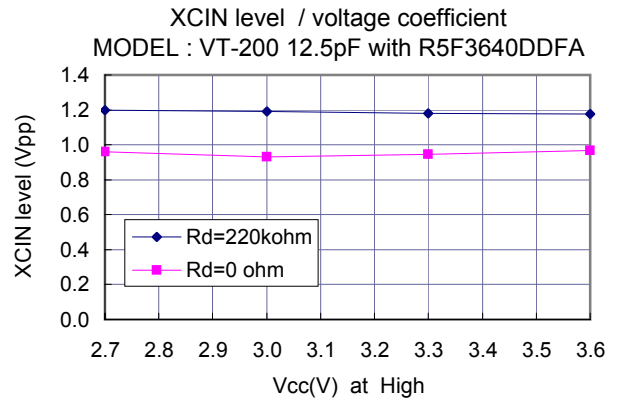
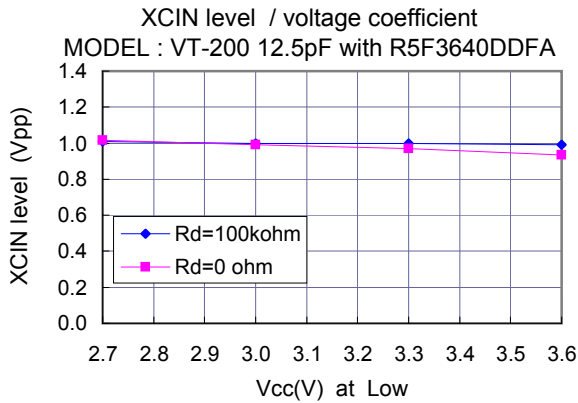
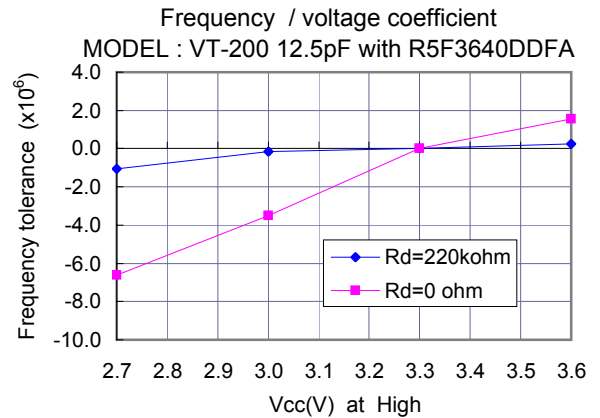
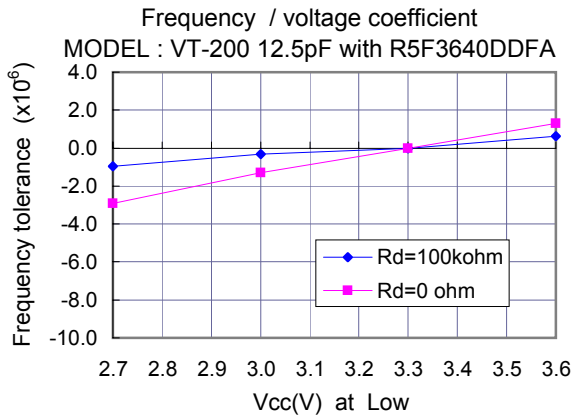

Evaluation of Subsystem Clock Oscillation Circuit

[R5F3640DDFA-100P] QFP(14x20) 0.65mm pitch

Measurement conditions : Vcc=3.3V at 25°C



Referential Data(2) : Negative feedback Rf*(Mohm) characteristics

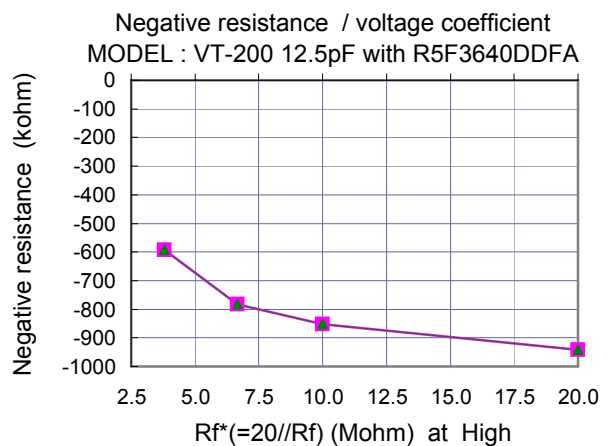
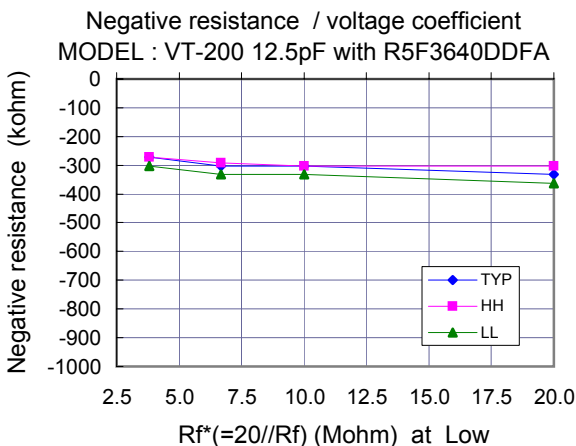
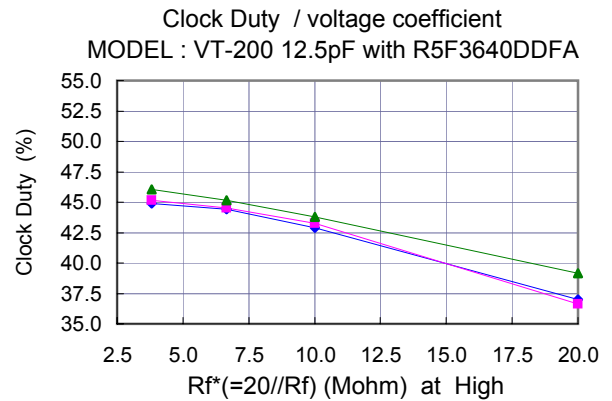
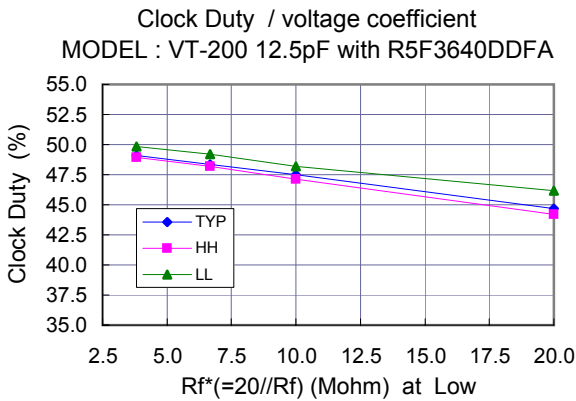
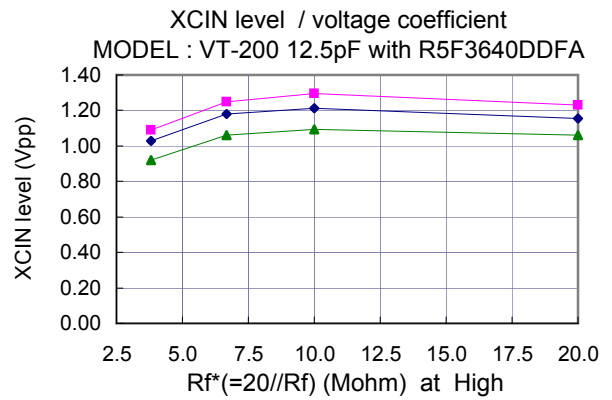
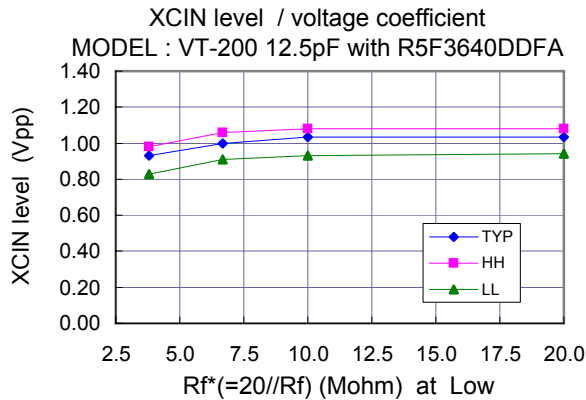
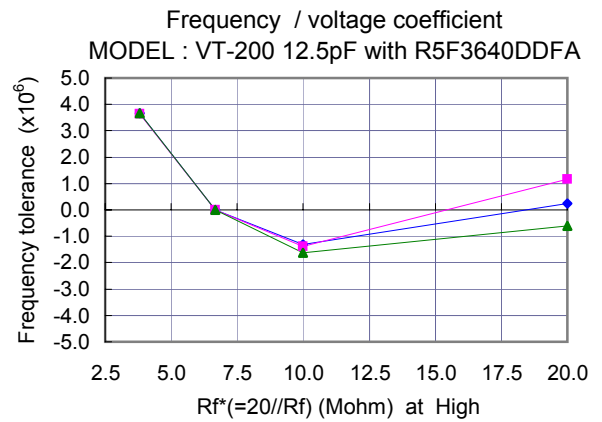
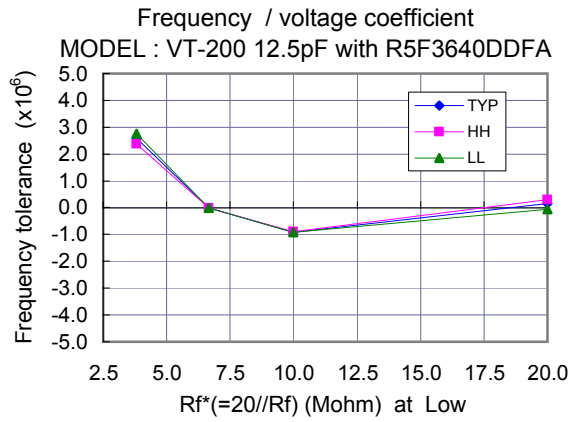

Evaluation of Subsystem Clock Oscillation Circuit

[R5F3640DDFA-100P] QFP(14x20) 0.65mm pitch

Measurement conditions : Vcc=3.3V at 25°C



Referential Data(3) : Circuit characteristics (TYP,HH,LL)

[Rf=open,Rd=220kohm,Cg=18pF,Cd=22pF at 25°C]

MODEL:VT-200 12.5pF with R5F3640DDFA

Mode	IC sample	df / f (x10 ⁻⁶)	DL(x10 ⁻⁶ W)	-RL (kohm	M(times)	Ts(sec)	XCIN(Vpp)	Duty(%)	Id(nA)
High	TYP	4.21	0.15	942	19	0.24	1.16	37.0	1475
	HH	5.52	0.17	942	19	0.26	1.23	36.7	1541
	LL	3.45	0.12	942	19	0.26	1.06	39.1	1353

[Rf=20Mohm,Rd=220kohm,Cg=18pF,Cd=22pF at 25°C]

MODEL:VT-200 12.5pF with R5F3640DDFA

Mode	IC sample	df / f (x10 ⁻⁶)	DL(x10 ⁻⁶ W)	-RL (kohm	M(times)	Ts(sec)	XCIN(Vpp)	Duty(%)	Id(nA)
High	TYP	2.66	0.16	852	17	0.29	1.21	42.9	1504
	HH	2.99	0.19	852	17	0.30	1.29	43.3	1590
	LL	2.44	0.13	852	17	0.30	1.09	43.8	1370

[Rf=4.7Mohm,Rd=220kohm,Cg=18pF,Cd=22pF at 25°C]

MODEL:VT-200 12.5pF with R5F3640ddfa

Mode	IC sample	df / f (x10 ⁻⁶)	DL(x10 ⁻⁶ W)	-RL (kohm	M(times)	Ts(sec)	XCIN(Vpp)	Duty(%)	Id(nA)
High	TYP	7.63	0.12	592	12	0.41	1.03	44.9	1410
	HH	8.00	0.13	592	12	0.42	1.09	45.2	1493
	LL	7.72	0.09	592	12	0.41	0.92	46.0	1284

[Rf=open,Rd=100kohm,Cg=18pF,Cd=22pF at 25°C]

MODEL:VT-200 12.5pF with R5F3640DDFA

Mode	IC sample	df / f (x10 ⁻⁶)	DL(x10 ⁻⁶ W)	-RL (kohm	M(times)	Ts(sec)	XCIN(Vpp)	Duty(%)	Id(nA)
Low	TYP	-1.07	0.12	332	7	0.36	1.03	44.7	1243
	HH	-0.92	0.13	302	6	0.34	1.08	44.2	1309
	LL	-0.98	0.10	362	7	0.33	0.94	46.2	1145

[Rf=20Mohm,Rd=100kohm,Cg=18pF,Cd=22pF at 25°C]

MODEL:VT-200 12.5pF with R5F3640DDFA

Mode	IC sample	df / f (x10 ⁻⁶)	DL(x10 ⁻⁶ W)	-RL (kohm	M(times)	Ts(sec)	XCIN(Vpp)	Duty(%)	Id(nA)
Low	TYP	-2.14	0.12	302	6	0.43	1.03	47.5	1257
	HH	-2.11	0.13	302	6	0.42	1.08	47.1	1323
	LL	-1.83	0.09	332	7	0.42	0.93	48.2	1158

[Rf=4.7Mohm,Rd=100kohm,Cg=18pF,Cd=22pF at 25°C]

MODEL:VT-200 12.5pF with R5F3640DDFA

Mode	IC sample	df / f (x10 ⁻⁶)	DL(x10 ⁻⁶ W)	-RL (kohm	M(times)	Ts(sec)	XCIN(Vpp)	Duty(%)	Id(nA)
Low	TYP	1.37	0.10	272	5	0.63	0.93	49.1	1191
	HH	1.16	0.11	272	5	0.60	0.98	48.9	1261
	LL	1.83	0.08	302	6	0.57	0.83	49.8	1091

*Referential Rd=0 ohm

[Rf=open,Rd=0 kohm,Cg=18pF,Cd=22pF at 25°C]

MODEL:VT-200 12.5pF with R5F3640DDFA

Mode	IC sample	df / f (x10 ⁻⁶)	DL(x10 ⁻⁶ W)	-RL (kohm	M(times)	Ts(sec)	XCIN(Vpp)	Duty(%)	Id(nA)
Low	TYP	0.89	0.13	332	7	0.41	1.09	49.4	1396
	HH	0.31	0.15	332	7	0.40	1.16	49.2	1478
	LL	1.43	0.10	362	7	0.37	0.97	50.5	1273

[Rf=20Mohm,Rd=0 kohm,Cg=18pF,Cd=22pF at 25°C]

MODEL:VT-200 12.5pF with R5F3640DDFA

Mode	IC sample	df / f (x10 ⁻⁶)	DL(x10 ⁻⁶ W)	-RL (kohm	M(times)	Ts(sec)	XCIN(Vpp)	Duty(%)	Id(nA)
Low	TYP	1.53	0.12	332	7	0.48	1.02	51.3	1370
	HH	0.73	0.13	302	6	0.50	1.10	51.1	1470
	LL	2.29	0.09	362	7	0.51	0.91	51.9	1259

[Rf=4.7Mohm,Rd=0 kohm,Cg=18pF,Cd=22pF at 25°C]

MODEL:VT-200 12.5pF with R5F3640DDFA

Mode	IC sample	df / f (x10 ⁻⁶)	DL(x10 ⁻⁶ W)	-RL (kohm	M(times)	Ts(sec)	XCIN(Vpp)	Duty(%)	Id(nA)
Low	TYP	8.85	0.08	302	6	0.69	0.86	48.7	1220
	HH	8.24	0.09	302	6	0.71	0.92	48.7	1294
	LL	10.16	0.06	362	7	0.67	0.75	51.5	1115

Evaluation of Subsystem Clock Oscillation Circuit

[R5F3640DDFA-100P] QFP(14x20) 0.65mm pitch

Measurement conditions : Vcc=3.3V at 25°C



Referential Data(4) : Signal wave characteristics (HH,LL)

Low mode;Rf=10Mohm,Rd=100kohm,Cg=18pF,Cd=22pF

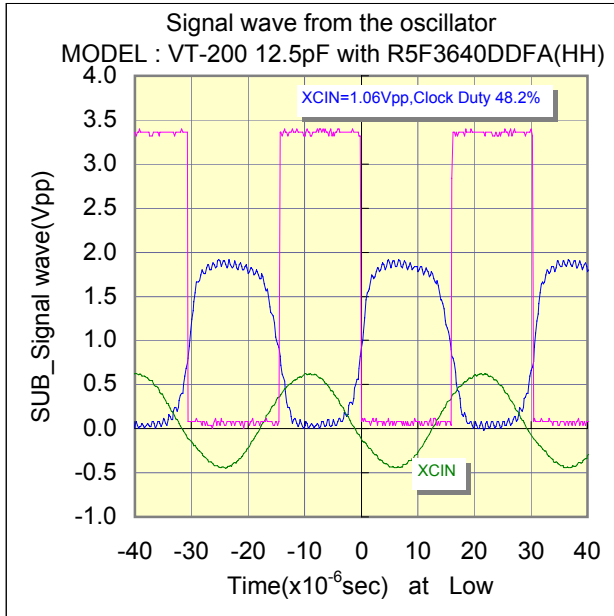

High mode;Rf=10Mohm,Rd=220kohm,Cg=18pF,Cd=22pF

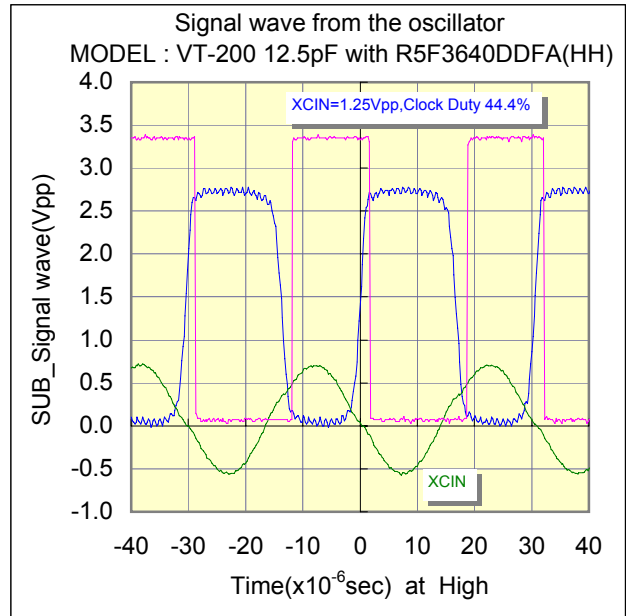

Low mode;Rf=10Mohm,Rd=100kohm,Cg=18pF,Cd=22pF

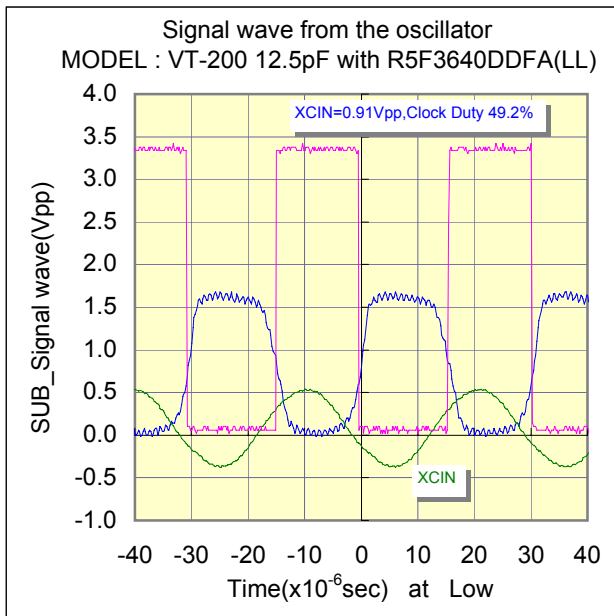

High mode;Rf=10Mohm,Rd=220kohm,Cg=18pF,Cd=22pF

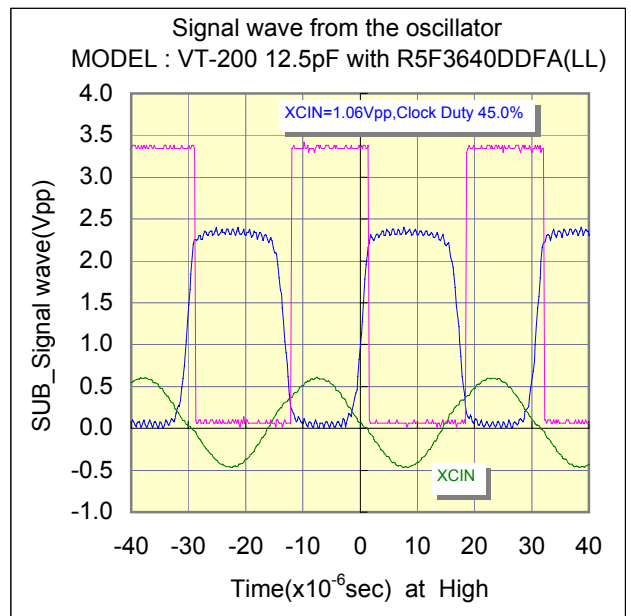

Evaluation of Subsystem Clock Oscillation Circuit

[R5F3640DDFA-100P] QFP(14x20) 0.65mm pitch

Measurement conditions : Vcc=3.3V at 25°C



Referential Data(5) : Start up time characteristics (HH,LL)

Low mode;Rf=10Mohm,Rd=100kohm,Cg=18pF,Cd=22pF

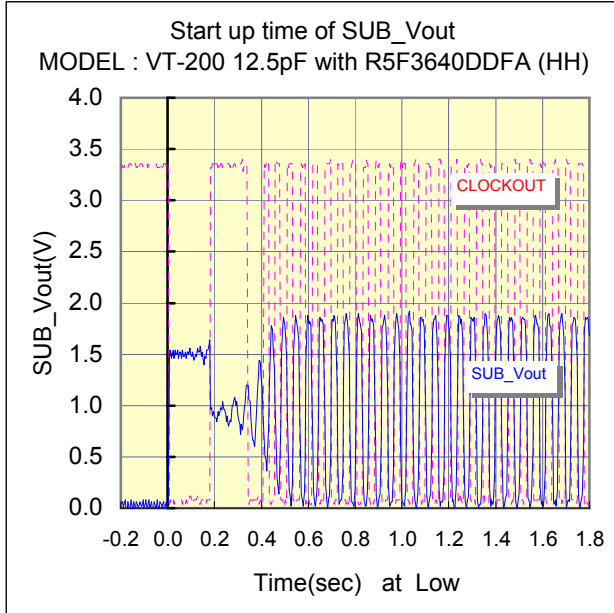

High mode;Rf=10Mohm,Rd=220kohm,Cg=18pF,Cd=22pF

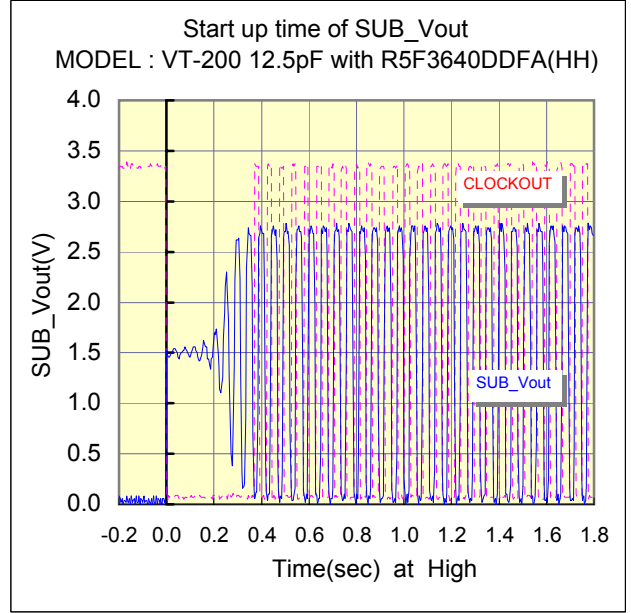

Low mode;Rf=10Mohm,Rd=100kohm,Cg=18pF,Cd=22pF

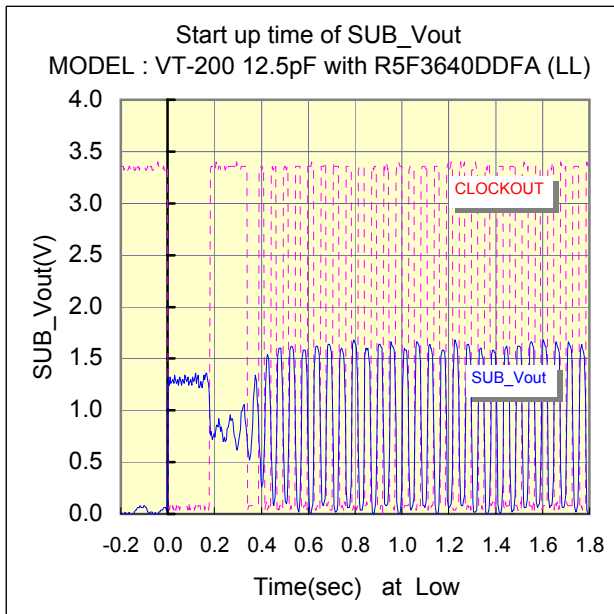

High mode;Rf=10Mohm,Rd=220kohm,Cg=18pF,Cd=22pF

