

Evaluation of Subsystem Clock Oscillation Circuit

[R5F212D8SNFP-80P] LQFP(12x12) 0.5mm pitch

Measurement conditions :3.3V



Model	:SSP-T7
Frequency	:Fo=32.768kHz
Frequency tolerance	:dF/Fo= +/-20x10 ⁻⁶
Load capacitance	:CL=12.5pF
Equivalent series resistance	:R1=65kohm max
Max. drive level	:DL=1x10 ⁻⁶ W max
Level of drive	:DL=0.1x10 ⁻⁶ W typ

FEATURES

- 1.Ultra thin type with 1.4mm Max.
- 2.SMD type suitable for automatic & high density surface mounting.
- 3.Plastic mold package containing highly reliable tubular type quartz crystal.
- 4.Excellent shock and heat resistance.
- 5.Cellular phones,PDA,Radio communication equipment, Portable applications etc.

RECOMMENDED SOLDERING PATTERN

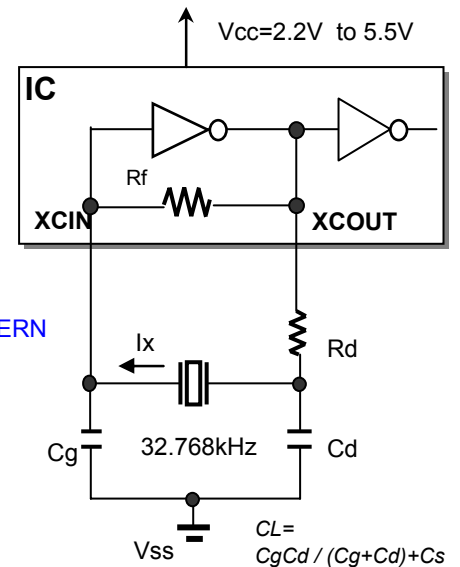
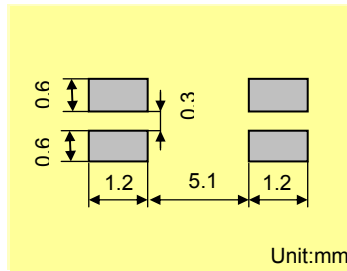

Remark) I_x : current through crystal

MODEL:SSP-T7 12.5pF with R5F212D8SNFP at 25°C

Key specifications	Low	High	Remarks
Negative feedback resistance : R_f (M ohm)	Built_in	Built_in	
Current control resistance : R_d (k ohm)	0	0	Control drive level & secure phase margin
Capacitance at gate : C_g (pF)	15	18	Optimal capacitance in response to CL
Capacitance at drain : C_d (pF)	15	18	($CL = C_d // C_g + \text{stray capacitance}$)

Circuit characteristics (at 25°C)	Low	High	Remarks
Matching Accuracy : df / f ($\times 10^{-6}$)	-0.5	0.7	Frequency offset volume at specified Vdd
Voltage Fluctuation : $\pm df / V$ ($\times 10^{-6}$)	0.2	0.3	Vdd $\pm 10\%$ (Standard operating voltage range)
Drive Level : DL ($\times 10^{-6}$ W)	0.16	0.14	$DL = I_x^2 R_e < 1 \times 10^{-6}$ W, $R_e = R_1(1 + C_o / CL)^2$
Negative resistance : $ -RL $ (kohm)	154	1144	5 times larger than R_{1MAX}
Oscillation allowance : M (times)	2.4	17.6	Judgemental standard of oscillation stability
Voltage of oscillation start : V_{strat} (V)	1.77	1.77	
Voltage of oscillation stop : V_{stop} (V)	1.74	1.74	
Oscillation start up time : T_s (sec)	1.27	0.44	Time to reach 90% of output level

Temperature characteristics of circuit		Low	High	Remarks
at -40°C	Variation : df / T ($\times 10^{-6}$)	-135	-135	Typ.Tp=25°C ($K = -3.5 \times 10^{-8} / ^\circ C^2$)
at +85°C	Variation : df / T ($\times 10^{-6}$)	-128	-128	Typ.Tp=25°C ($K = -3.5 \times 10^{-8} / ^\circ C^2$)

The above mentioned value is only for your reference. The value is for the arbitrary samples and does not guarantee the product's characteristics. Please review and check above parameters at customer's end.

Seiko Instruments USA Inc.

2990,West Lomita Blvd., Torrance, CA 90505, U.S.A
Telephone :+1 310-517-7771 Facsimile :+1 310-517-7792
Email :crystals@siu-la.com

Seiko Instruments GmbH

Siemensstrasse 9,D-63263 Neu-Isenburg,Germany
Telephone :+49-6102-297-0 Facsimile :+49-6102-297-320
Email :info@seiko-instruments.de

Seiko Instruments Inc.

1-8,Nakase,Mihama-ku,Chiba-shi,Chiba 261-8507,Japan
Facsimile :+81-43-211-8030
E-mail :component@sii.co.jp



We value the "takumi" spirit.

Seiko Instruments Inc.

Phone:+81-43-211-1207(Direct)

Evaluation of Subsystem Clock Oscillation Circuit

[R5F212D8SNFP] LQFP(12x12) 0.5mm pitch

Measurement conditions :3.3V



Test Data at 25°C

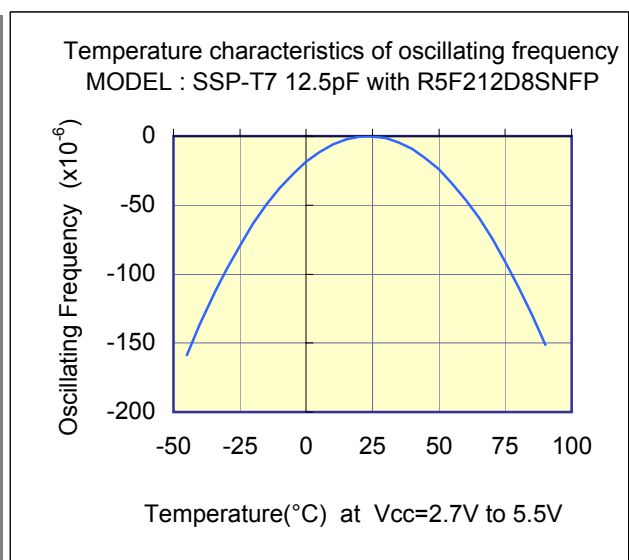
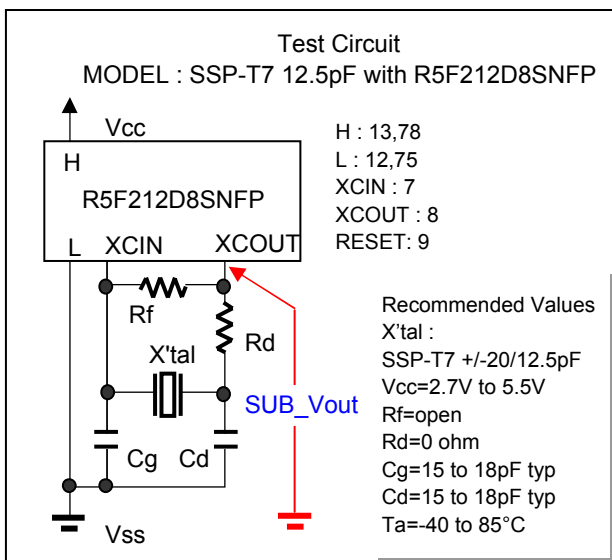
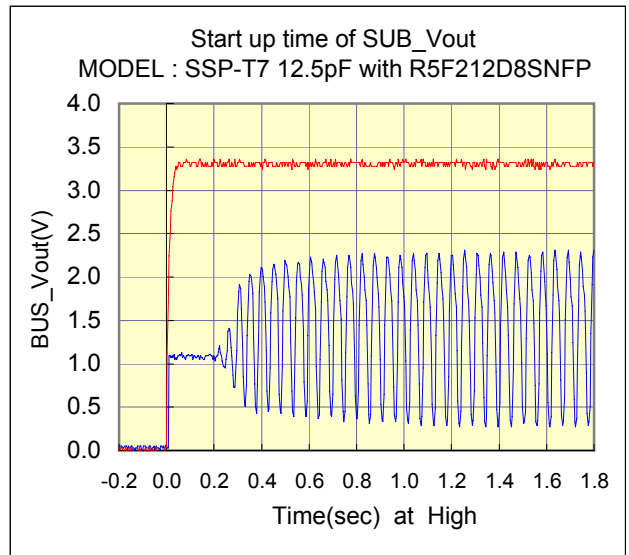
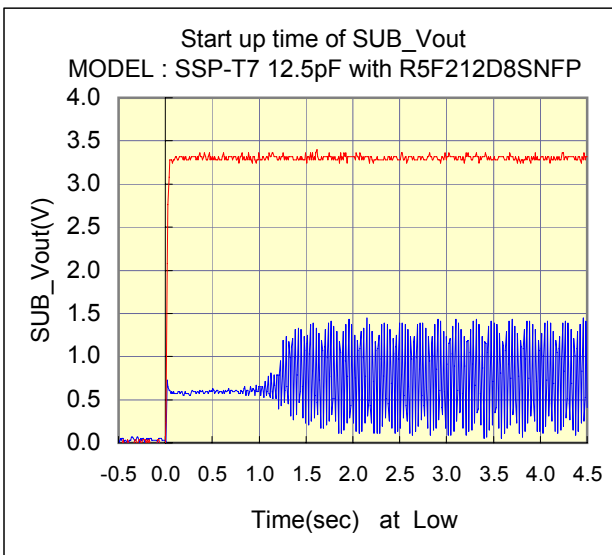
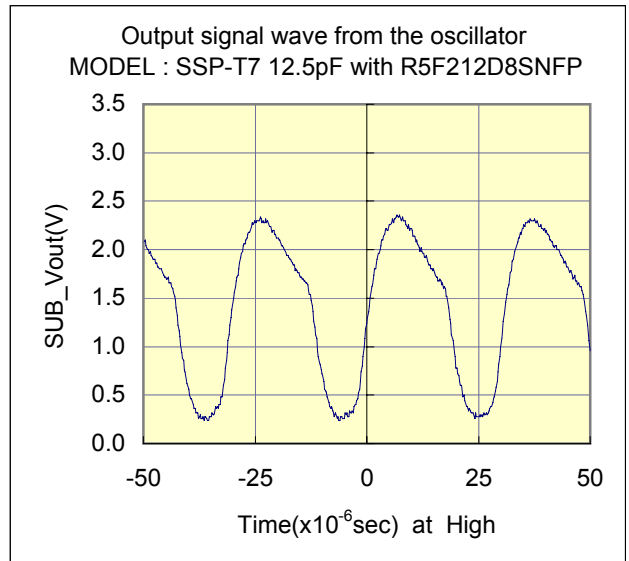
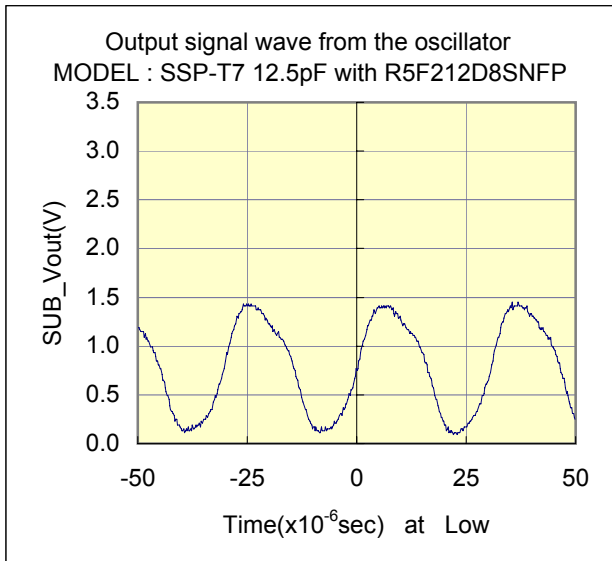

Evaluation of Subsystem Clock Oscillation Circuit

[R5F212D8SNFP-80P] LQFP(12x12) 0.5mm pitch

Measurement conditions :3.3V



Test Data : Temperature characteristics

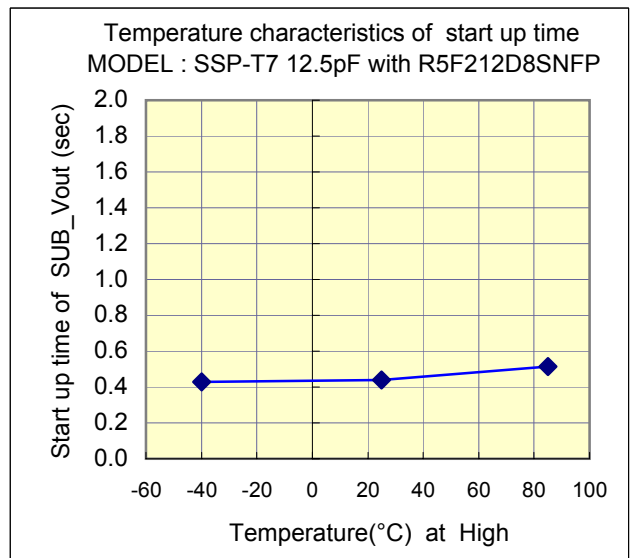
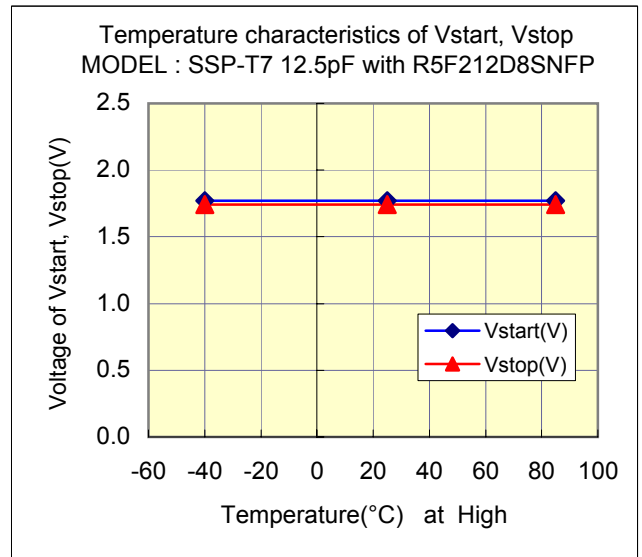
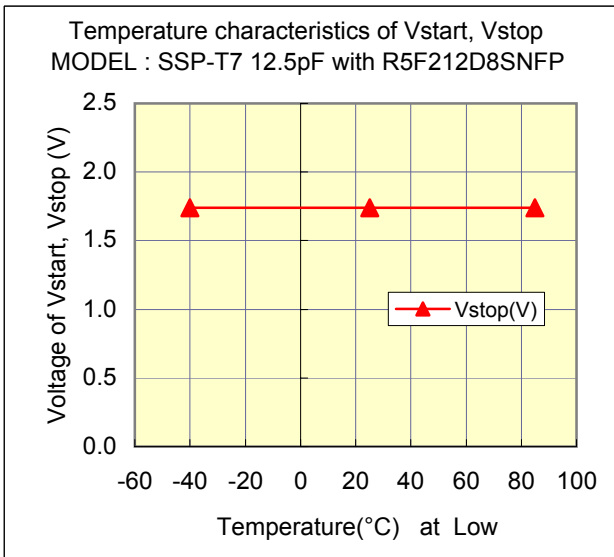
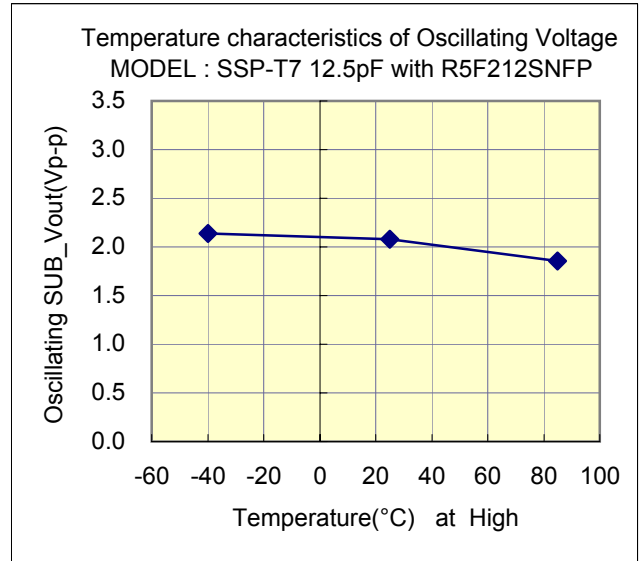
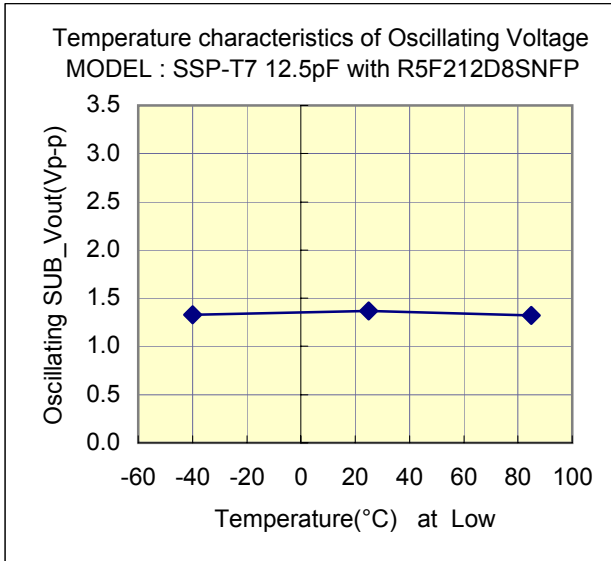

Evaluation of Subsystem Clock Oscillation Circuit

[R5F212D8SNFP-80P] LQFP(12x12) 0.5mm pitch

Measurement conditions :3.3V



Referential components layout(see Figure 1)

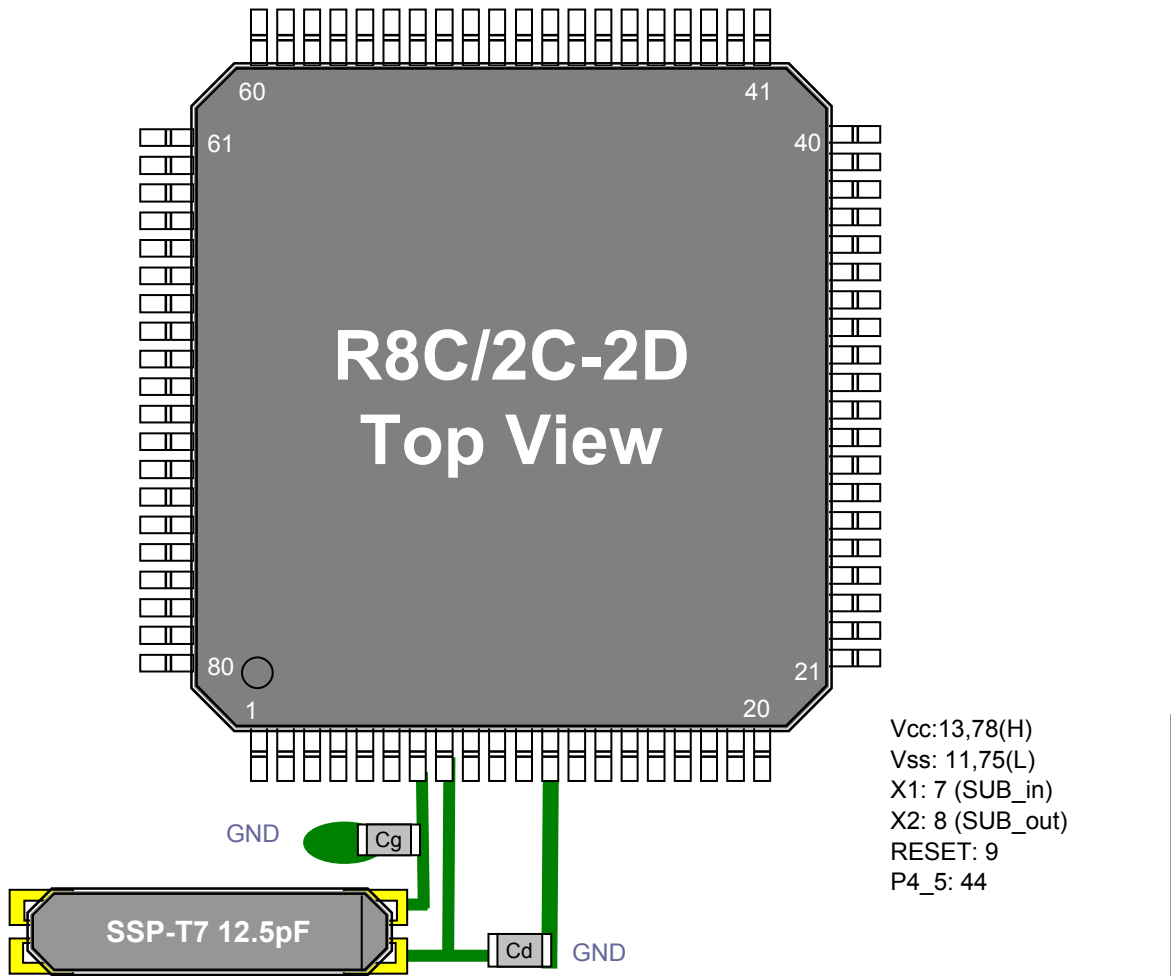

Figure 1 Referential components layout

Notes Board Design

When using a crystal resonator, place the resonator and its load capacitors as close as possible to SUB_in and SUB_out pins.

Other signal lines should be routed away from the resonator circuit to prevent induction from interfering with correct oscillation (see figure 2).

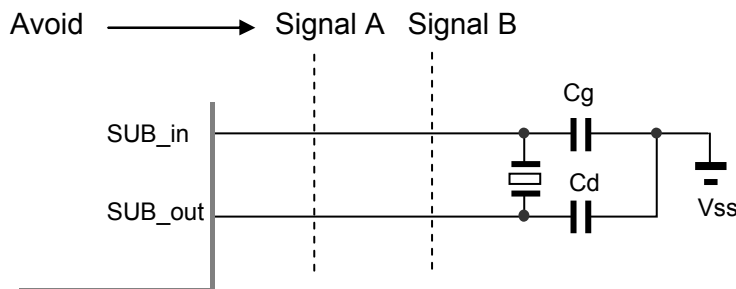

Figure 2 Example of Incorrect Board Design

Evaluation of Subsystem Clock Oscillation Circuit

[R5F212D8SNFP-80P] LQFP(12x12) 0.5mm pitch

Measurement conditions :3.3V



[Evaluation Sample : SSP-T7 12.5pF at 25°C]

SAMPLE	No.	CL (pF)	Fo (Hz)	fr (Hz)	R1(kohm)	Co (pF)	C1 (fF)	Q(k)
SSP-T7 12.5pF	1	12.5	32768.14	32765.66	38	0.88	2.025	63.2
	2	12.5	32768.06	32765.60	45.1	0.84	2.003	53.8
	3	12.5	32768.16	32765.70	39.8	0.85	2.004	60.9

[IC Test Data : IC samples Rd=0 ohm,Cg=15 to 18pF,Cd=15 to 18pF at 25°C]

MODE	IC samples	Fosc (Hz)	df / f (x10 ⁻⁶)	DL(x10 ⁻⁶ W)	-RL (kohm)	Vstart (V)	Ts(sec)
High	TYP	32768.164	0.73	0.14	1144	1.77	0.44
	HH	32768.167	0.82	0.15	1244	1.77	0.44
	HL	32768.230	2.75	0.14	1244	1.70	0.47
	LH	32768.168	0.85	0.14	1144	1.68	0.46
	LL	32768.200	1.83	0.13	1144	1.72	0.48
Low	TYP	32768.124	-0.49	0.16	154	1.77	1.27
	HH	32768.118	-0.67	0.18	144	1.77	1.46
	HL	32768.175	1.07	0.16	374	1.70	0.74
	LH	32768.115	-0.76	0.14	126	1.68	1.48
	LL	32768.140	0.00	0.13	224	1.72	1.20

Remark (see figure 3)

$$F_o = f_r \times \left\{ \frac{C_1}{2 \times (C_o + C_L)} + 1 \right\} \text{ (Hz)}$$

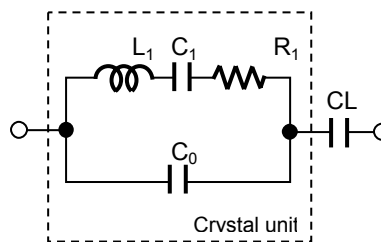

Fo : Load resonance frequency
 fr : Resonance frequency
 R1 : Motional resistance
 C1 : Motional capacitance
 Co : Shunt capacitance
 CL : Load Capacitance

Figure 3 Equivalent circuit of crystal unit, and CL

Remark (see figure 4)

Approximate formula of the load capacitance of the circuit CL.

$$CL = \frac{C_g \times C_d}{C_g + C_d} + C_s \text{ (pF)}$$

Where Cs(=2 to 4pF) Stands for stray capacitance of the circuit.

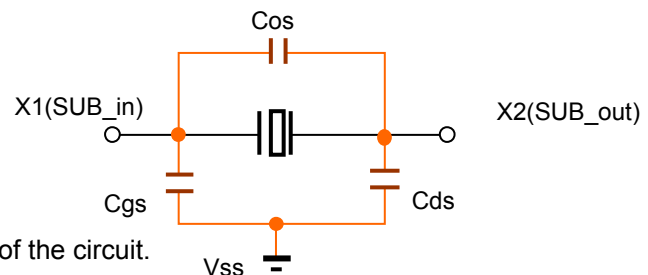

Cos : X1_X2 Stray capacitance
 Cgs : X1_Vss Stray capacitance
 Cds : X2_Vss Stray capacitance

Figure 4 Stray capacitance Cos,Cgs,Cds of the circuit

Resonator circuit constants will differ depending on the resonator element, stray capacitance in its interconnecting circuit, and other factors. Suitable constants should be determined in consultation with the resonator element manufacturer.

Evaluation of Subsystem Clock Oscillation Circuit

[R5F212D8SNFP] LQFP(12x12) 0.5mm pitch

Measurement conditions : Vdd=1.8V to 5.5V at 25°C

Referential Data : Voltage characteristics

Frequency / voltage coefficient
MODEL : SSP-T7 12.5pF with R5F212D8SNFP

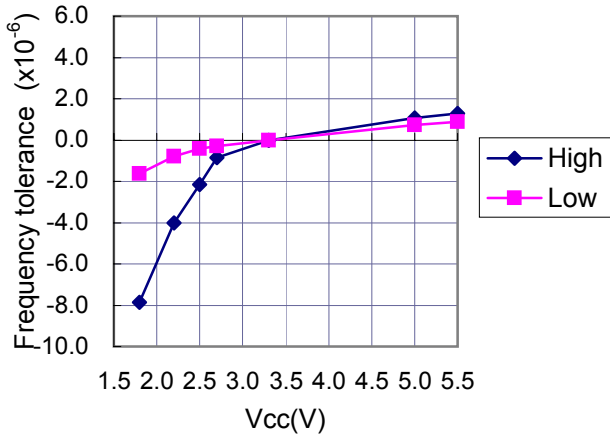

SUB_Vout / voltage coefficient
MODEL : SSP-T7 12.5pF with R5F212D8SNFP

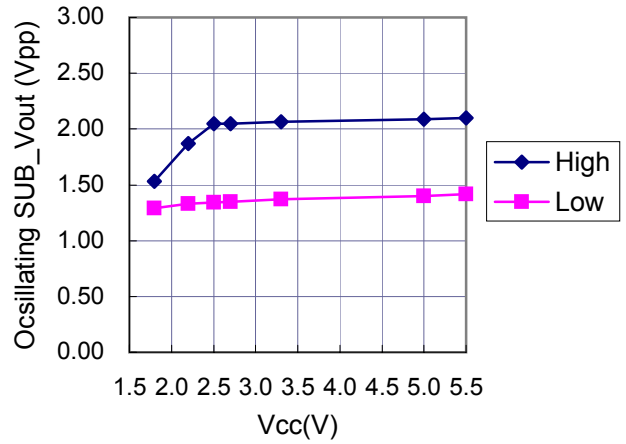

Negative resistance / voltage coefficient
MODEL : SSP-T7 12.5pF with R5F212D8SNFP

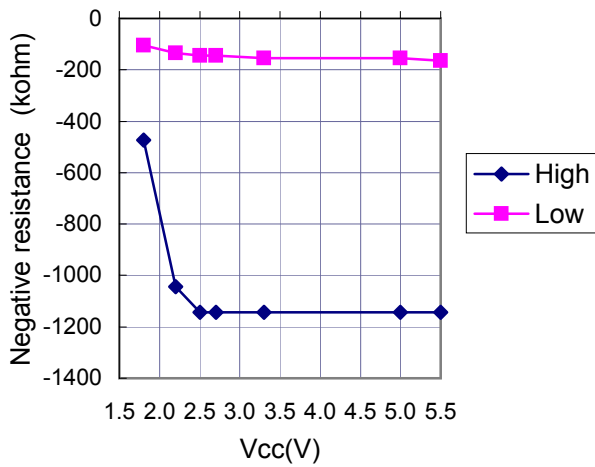

Start up time / voltage coefficient
MODEL : SSP-T7 12.5F with R5F212D8SNFP

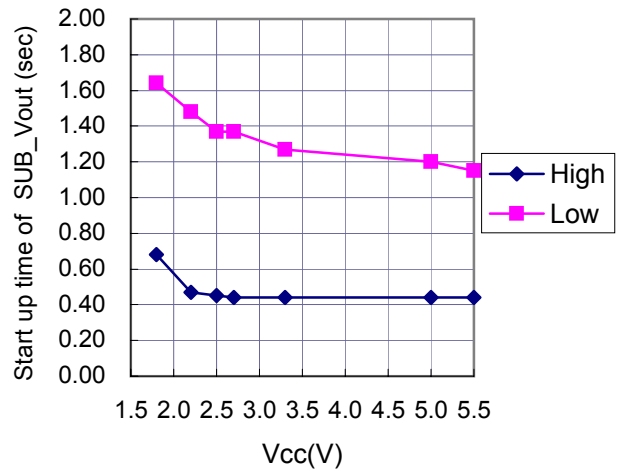

Cd charge current / voltage coefficient
MODEL : SSP-T7 12.5pF with R5F212D8SNFP

