

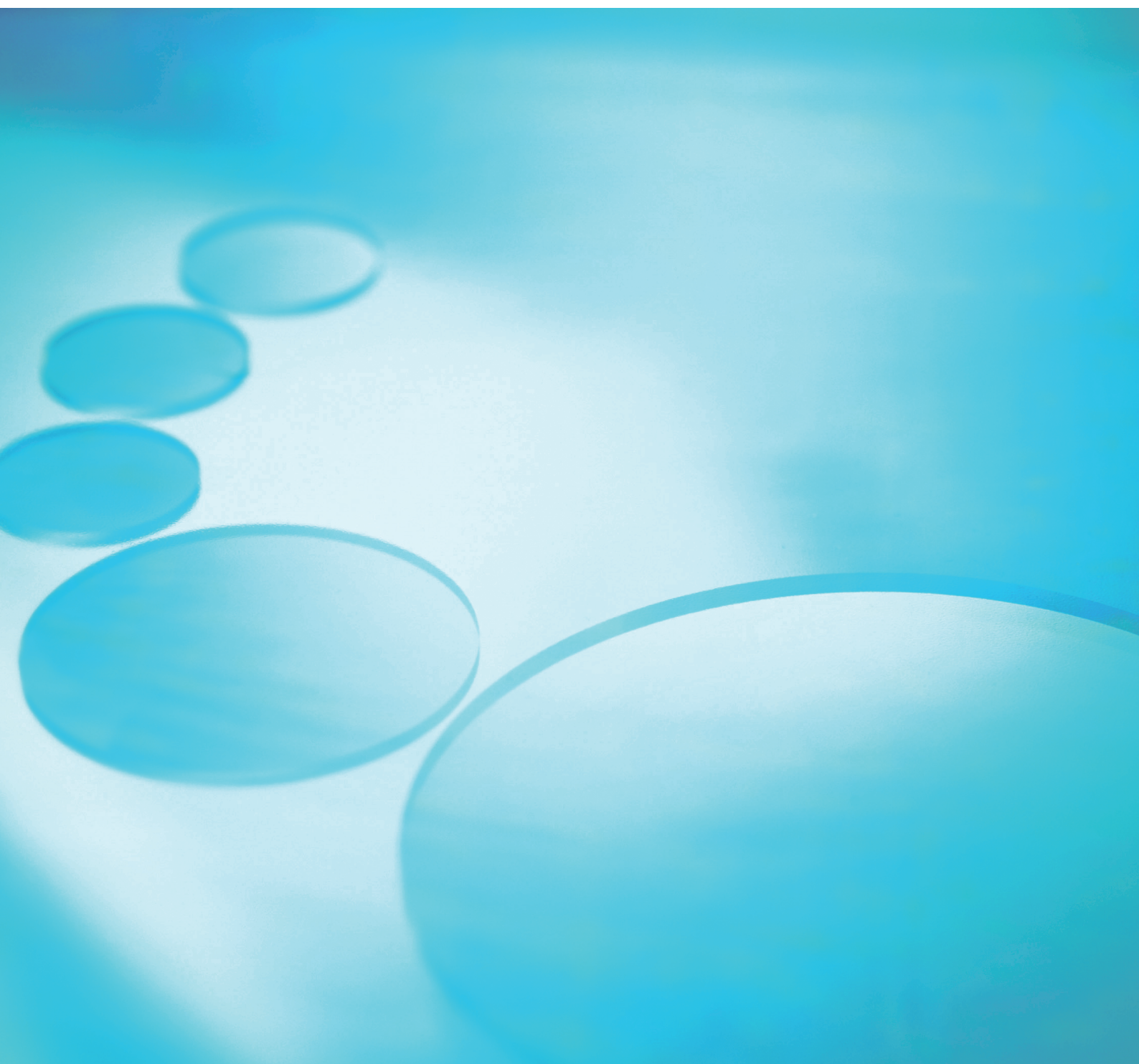

# Quartz Crystal

Product Catalogue

2013





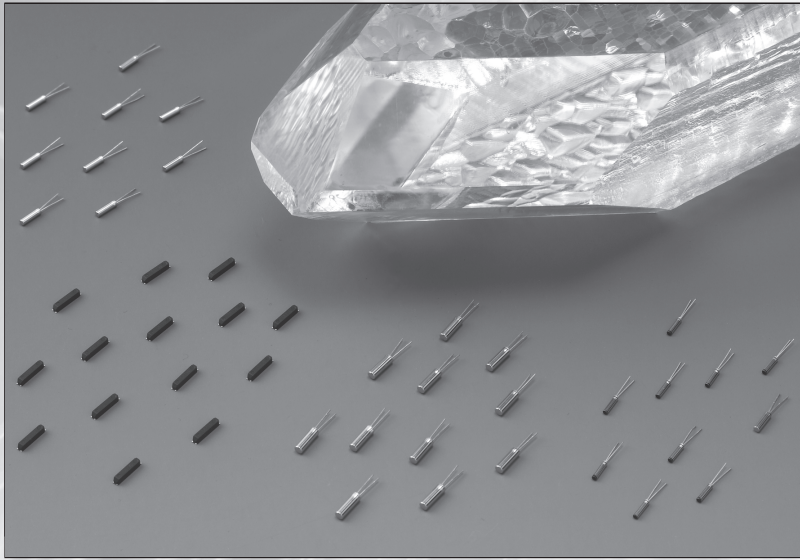

## Contents

### SC Series

Compact SMD type Quartz Crystal Units for Low Frequencies (32×15mm) .....	4
Compact SMD type Quartz Crystal Units for Low Frequencies (20×12mm) .....	5

### SSP-T Series

SMD type low CL resonator for low-power microcontrollers .....	6
Surface Mount Quartz Crystal Units for Low Frequencies .....	7

### VT Series

Cylinder-type low CL resonator for low-power microcontrollers .....	8
Quartz Crystal Units for Low Frequencies (2.0 $\phi$ ) .....	9
Quartz Crystal Units for Low Frequencies (1.2 $\phi$ ) .....	10

### Quartz Crystal Unit Handling

Precautions .....	11
Oscillation Circuit Design Precautions.....	13
Packing.....	15
Environmental Activities .....	17



## SC-32S **NEW**

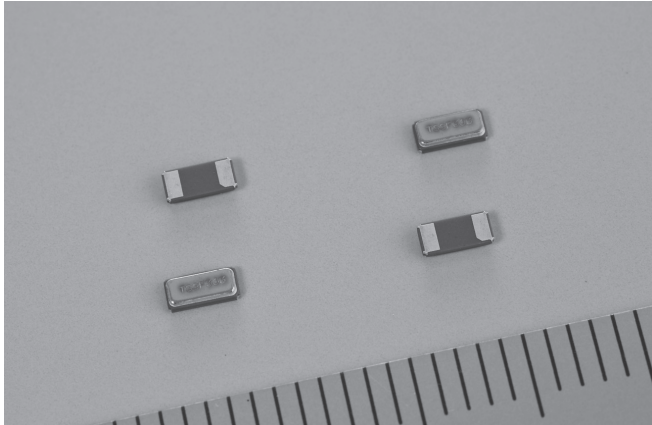

### FEATURES

- Ultra thin type with height 0.75mm.
- SMD type suitable for automatic & high density surface mounting.
- Ceramic package containing highly reliable photolithographic processed quartz crystal.
- Excellent shock and heat resistance.
- Complete Pb-free.

### APPLICATIONS

Smartphones, Cellular Phones, PHS, Tablet PC, DVC, Radio Communication Equipment, Portable Applications etc.

### STANDARD SPECIFICATIONS

Conditions without notice (Temperature: +25±2°C, DL: 0.1μW)

Item	Symbol	Specifications	Conditions / Notes
Nominal Frequency	f_nom	32.768kHz	
Frequency Tolerance	f_tol	±20 x 10 <sup>-6</sup>	
Turnover Temperature	Ti	+25±5°C	
Parabolic Coefficient	B	(-3.0±1.0) x 10 <sup>-8</sup> /°C <sup>2</sup>	
Load Capacitance	CL	7.0pF / 9.0pF / 12.5pF	
Motional Resistance (ESR)	R <sub>1</sub>	70kΩ max.	
Absolute Maximum Drive Level	DLmax	0.5μW	"0.1μW max." is also available.
Level of Drive	DL	0.1μW	
Shunt Capacitance	C <sub>0</sub>	1.0pF typ.	
Frequency Ageing	f_age	±3 x 10 <sup>-6</sup>	+25±3°C, First Year
Operating Temperature	T_use	-40°C to +85°C	
Storage Temperature	T_stg	-55°C to +125°C	Piece part basis

### DIMENSIONS

SC-32S

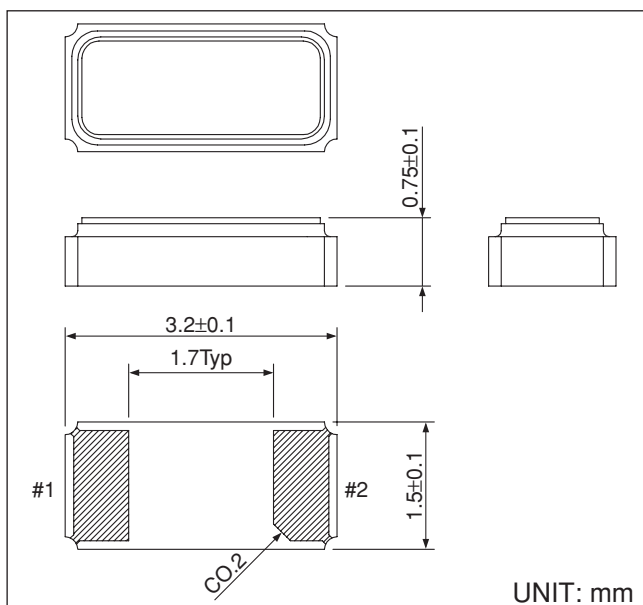

### INTERNAL LEAD CONNECTION

SC-32S

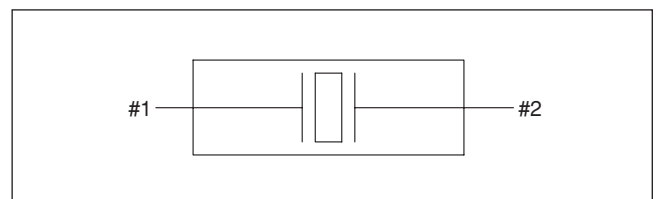

### RECOMMENDED SOLDERING PATTERN

SC-32S

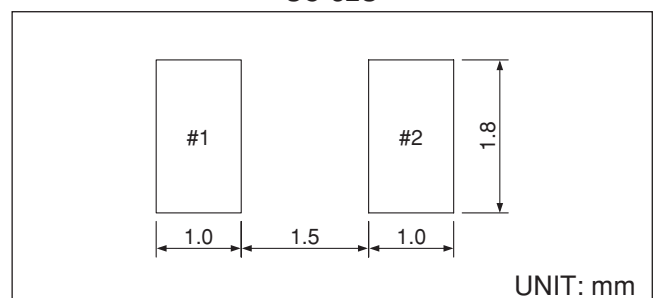

**Remark** Please make sure there is no pattern under SC-32S on the circuit board.

# SC-20S **NEW**

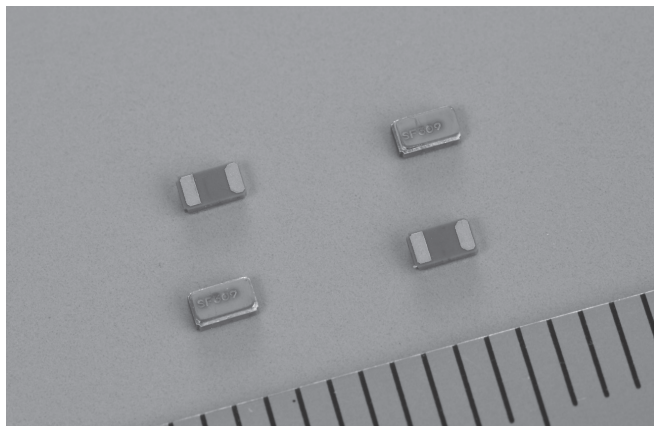

## FEATURES

- Ultra thin type with height 0.6mm max.
- SMD type suitable for automatic & high density surface mounting.
- Ceramic package containing highly reliable photolithographic processed quartz crystal.
- Excellent shock and heat resistance.
- Complete Pb-free.

## APPLICATIONS

Smartphones, Cellular Phones, PHS, Tablet PC, DVC, Radio Communication Equipment, Portable Applications etc.

## STANDARD SPECIFICATIONS

Conditions without notice (Temperature: +25±2°C, DL: 0.1μW)

Item	Symbol	Specifications	Conditions / Notes
Nominal Frequency	f_nom	32.768kHz	
Frequency Tolerance	f_tol	±20 x 10 <sup>-6</sup>	
Turnover Temperature	Ti	+25±5°C	
Parabolic Coefficient	B	(-3.0±1.0) x 10 <sup>-8</sup> /°C <sup>2</sup>	
Load Capacitance	CL	(7.0pF) / 9.0pF / 12.5pF	
Motional Resistance (ESR)	R <sub>1</sub>	90kΩ max.	
Absolute Maximum Drive Level	DLmax	0.5μW	"0.1μW max." is also available.
Level of Drive	DL	0.1μW	
Shunt Capacitance	C <sub>0</sub>	1.3pF typ.	
Frequency Ageing	f_age	±3 x 10 <sup>-6</sup>	+25±3°C, First Year
Operating Temperature	T_use	-40°C to +85°C	
Storage Temperature	T_stg	-55°C to +125°C	Piece part basis

## DIMENSIONS

SC-20S

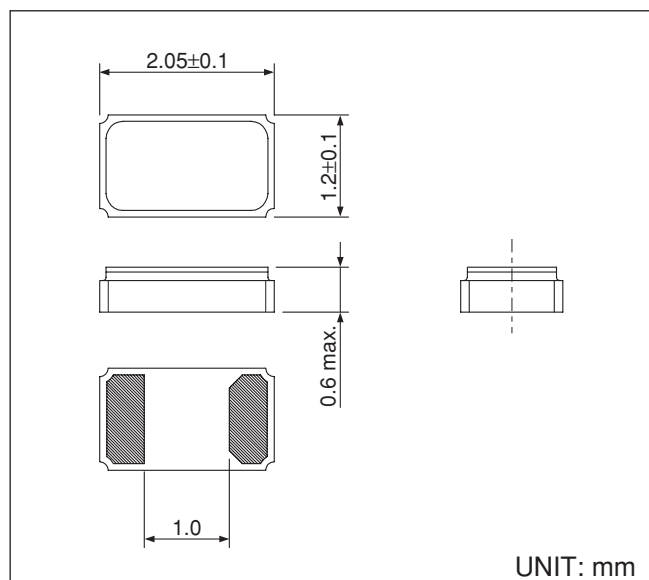

## INTERNAL LEAD CONNECTION

SC-20S

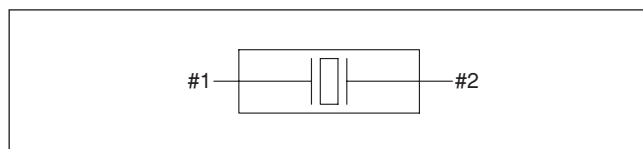

## RECOMMENDED SOLDERING PATTERN

SC-20S

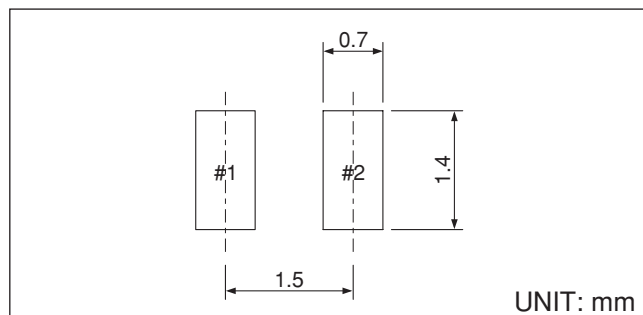

**Remark** Please make sure there is no pattern under SC-20S on the circuit board.

## SSP-T7-FL (SMD type low CL resonator for low-power microcontrollers)

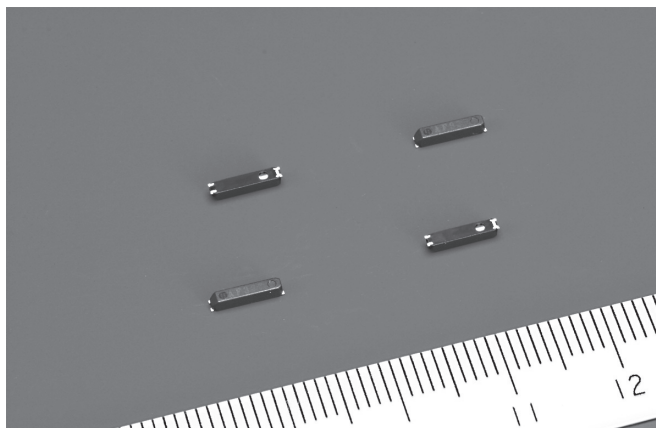

### FEATURES

- Consumes one tenth the standby power of general crystal resonators (with a load capacitance of 12.5 pF).
- Excellent low drive level characteristics.
- RoHS directive compliant.

### APPLICATIONS

- Consumer-electronics products for saving standby energy consumption.
- Battery operated devices requiring a long battery life.

### STANDARD SPECIFICATIONS

Conditions without notice (Temperature: +25±2°C, DL: 0.1μW)

Item	Symbol	Specifications	Conditions / Notes
Nominal Frequency	f_nom	32.768kHz	
Frequency Tolerance	f_tol	±20 x 10 <sup>-6</sup>	
Turnover Temperature	Ti	+25±5°C	
Parabolic Coefficient	B	(-3.5±1.0) x 10 <sup>-8</sup> /°C <sup>2</sup>	
Load Capacitance	C <sub>L</sub>	3.7pF, 4.4pF, 6.0pF	
Motional Resistance (ESR)	R <sub>1</sub>	65kΩ max.	
Absolute Maximum Drive Level	DLmax.	1μW	
Level of Drive	D <sub>L</sub>	0.01μW	
Shunt Capacitance	C <sub>0</sub>	0.8pF typ.	
Frequency Ageing	f_age	±3 x 10 <sup>-6</sup>	+25±3°C, First Year
Operating Temperature	T_use	-40°C to +85°C	
Storage Temperature	T_stg	-55°C to +125°C	Piece part basis

### CAUTION

The SSP-T7-FL is designed for use in ultra-low-power microcontrollers. Do not use this resonator in regular microcontrollers as it might cause problems with oscillation.

# SSP-T7-F

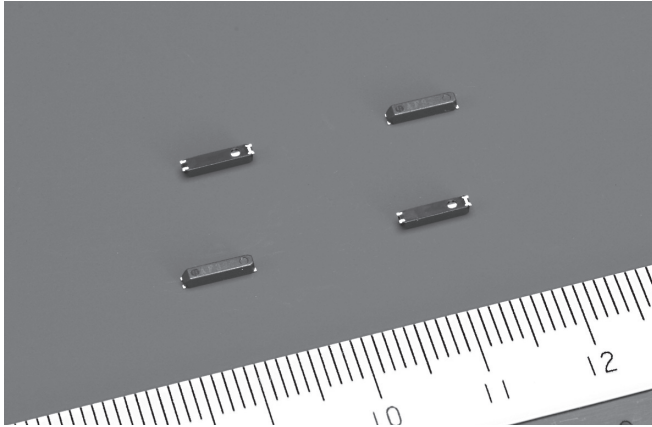

## FEATURES

- Ultra thin type with height 1.4mm max.
- SMD type suitable for automatic & high density surface mounting.
- Plastic mold package containing highly reliable tubular type quartz crystal.
- Excellent shock and heat resistance.
- RoHS directive compliant.

## APPLICATIONS

Cellular Phones, Tablet PC, DSC, Car Audio, GPS Module, FM Tuner Module, ZigBee, Glucose Meter, Payment Terminal, Clock Source for Micro-Computers, Portable Applications etc.

## STANDARD SPECIFICATIONS

Conditions without notice (Temperature: +25±2°C, DL: 0.1μW)

Item	Symbol	Specifications	Conditions / Notes
Nominal Frequency	f_nom	32.768kHz	
Frequency Tolerance	f_tol	±20 x 10 <sup>-6</sup>	
Turnover Temperature	Ti	+25±5°C	
Parabolic Coefficient	B	(-3.5±1.0) x 10 <sup>-8</sup> /°C <sup>2</sup>	
Load Capacitance	CL	7.0pF / 12.5pF	
Motional Resistance (ESR)	R <sub>1</sub>	65kΩ max.	
Absolute Maximum Drive Level	DLmax	1μW	
Level of Drive	DL	0.1μW	
Shunt Capacitance	C <sub>0</sub>	0.8pF typ.	
Frequency Ageing	f_age	±3 x 10 <sup>-6</sup>	+25±3°C, First Year
Operating Temperature	T_use	-40°C to +85°C	
Storage Temperature	T_stg	-55°C to +125°C	Piece part basis

## DIMENSIONS

SSP-T7-FL / SSP-T7-F

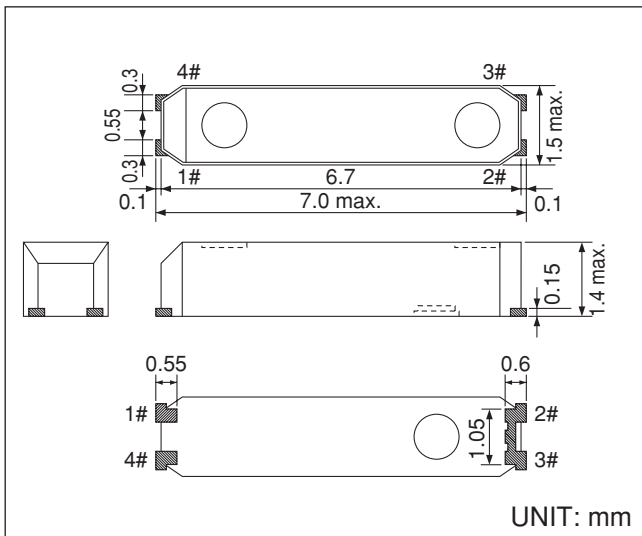

## INTERNAL LEAD CONNECTION

SSP-T7-FL / SSP-T7-F

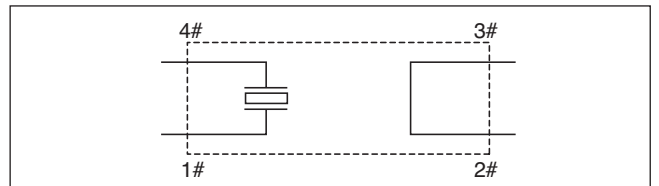

## RECOMMENDED SOLDERING PATTERN

SSP-T7-FL / SSP-T7-F

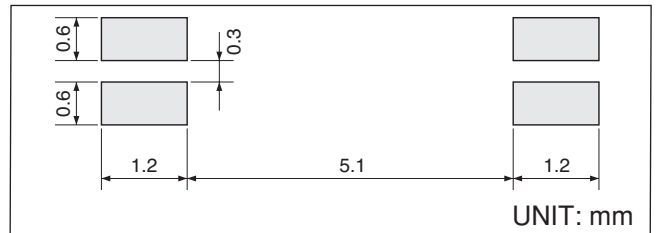

- Remarks**
1. Do not connect #2 and #3 to external device and GND.
  2. The part of the cylinder inside resin mold may be sometimes exposed, however, it does not affect the characteristics of crystal unit.
  3. Please make sure that there is no pattern under SSP-T7-F on the circuit board.

## VT-200-FL (Cylinder-type low CL resonator for low-power microcontrollers)

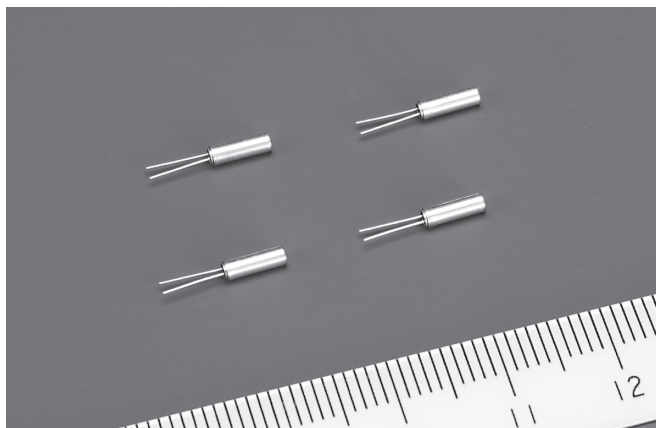

### FEATURES

- Consumes one tenth the standby power of general crystal resonators (with a load capacitance of 12.5 pF).
- Excellent low drive level characteristics.
- RoHS directive compliant.
- Complete Pb-free.

### APPLICATIONS

- Consumer-electronics products for saving standby energy consumption.
- Battery operated devices requiring a long battery life.

### STANDARD SPECIFICATIONS

Conditions without notice (Temperature: +25±2°C, DL: 0.1μW)

Item	Symbol	Specifications	Conditions / Notes
Nominal Frequency	f_nom	32.768kHz	
Frequency Tolerance	f_tol	±20 x 10 <sup>-6</sup>	
Turnover Temperature	Ti	+25±5°C	
Parabolic Coefficient	B	(-3.5±0.8) x 10 <sup>-8</sup> /°C <sup>2</sup>	
Load Capacitance	C <sub>L</sub>	3.7pF, 4.4pF, 6.0pF	
Motional Resistance (ESR)	R <sub>1</sub>	50kΩ max.	
Absolute Maximum Drive Level	DLmax.	1μW	
Level of Drive	DL	0.01μW	
Shunt Capacitance	C <sub>0</sub>	0.9pF typ.	
Frequency Ageing	f_age	±3 x 10 <sup>-6</sup>	+25±3°C, First Year
Operating Temperature	T_use	-40°C to +85°C	
Storage Temperature	T_stg	-40°C to +85°C	Piece part basis

### CAUTION

The VT-200-FL is designed for use in ultra-low-power microcontrollers. Do not use this resonator in regular microcontrollers as it might cause problems with oscillation.



# VT-150-F/VT-200-F

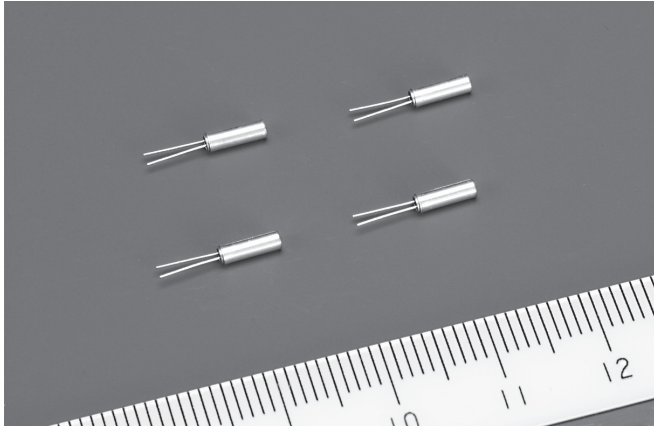

## FEATURES

- Compact tubular package.
- Photolithographic process.
- Excellent shock resistance and environmental characteristics.
- RoHS directive compliant.
- Complete Pb-free.

## APPLICATIONS

Real Time Clocks, Timers, Water/Electricity/Gas Meter, Remote-Controllers, Portable Applications

## STANDARD SPECIFICATIONS

Conditions without notice (Temperature: +25±2°C, DL: 0.1μW)

Item	Symbol	Specifications	Conditions / Notes
Nominal Frequency	f_nom	32.768kHz	
Frequency Tolerance	f_tol	(±5 x 10 <sup>-6</sup> ), ±10 x 10 <sup>-6</sup> , ±20 x 10 <sup>-6</sup>	
Turnover Temperature	Ti	+25±5°C	
Parabolic Coefficient	B	(-3.5±0.8) x 10 <sup>-8</sup> /°C <sup>2</sup>	
Load Capacitance	CL	4.5 to 12.5pF	
Motional Resistance (ESR)	R1	50kΩ max.	
Absolute Maximum Drive Level	DLmax	1μW	
Level of Drive	DL	0.1μW	
Shunt Capacitance	Co	0.9pF typ.	
Frequency Ageing	f_age	±3 x 10 <sup>-6</sup>	+25±3°C, First Year
Operating Temperature	T_use	-10°C to +60°C	
Storage Temperature	T_stg	-30°C to +70°C	Piece part basis

## DIMENSIONS

VT-150-F

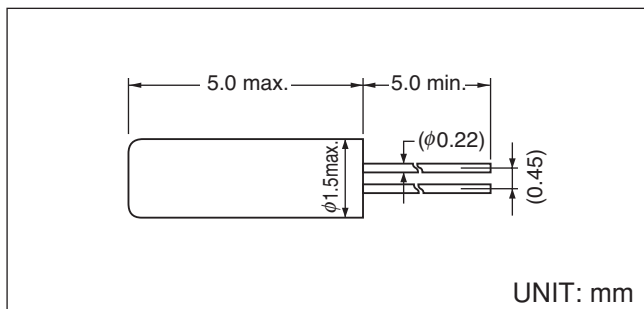

VT-200-FL / VT-200-F

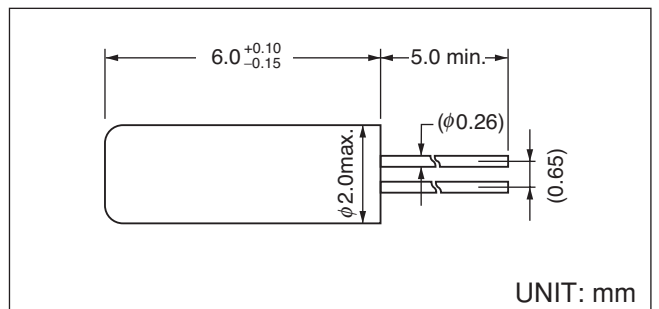

## VT-120-F

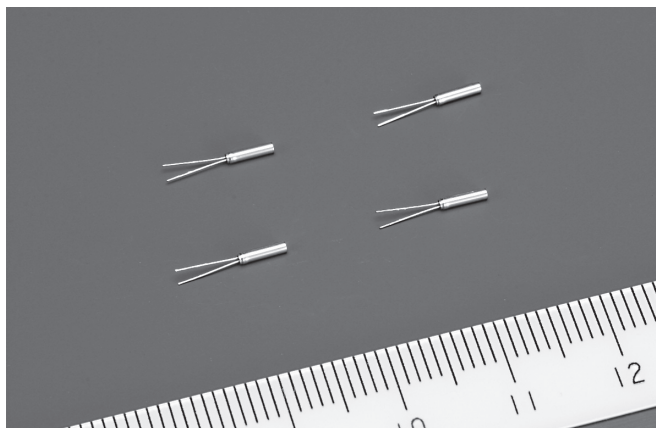

### FEATURES

- Compact 1.2 $\phi$  tubular package.
- Photolithographic process.
- Excellent shock resistance and environmental characteristics.
- RoHS directive compliant.
- Complete Pb-free.

### APPLICATIONS

Clock Source for Micro-Computers,  
Small/Thin Watches.

### STANDARD SPECIFICATIONS

Conditions without notice (Temperature: +25 $\pm$ 2 $^{\circ}$ C, DL: 0.1 $\mu$ W)

Item	Symbol	Specifications	Conditions / Notes
Nominal Frequency	f_nom	32.768kHz	
Frequency Tolerance	f_tol	$\pm 20 \times 10^{-6}$	
Turnover Temperature	Ti	+25 $\pm$ 5 $^{\circ}$ C	
Parabolic Coefficient	B	$(-3.5 \pm 1.0) \times 10^{-8}/^{\circ}\text{C}^2$	
Load Capacitance	CL	6.0 to 12.5pF	
Motional Resistance (ESR)	R1	50k $\Omega$ max.	
Absolute Maximum Drive Level	DLmax	1 $\mu$ W	
Level of Drive	DL	0.1 $\mu$ W	
Shunt Capacitance	C0	0.8pF typ.	
Frequency Ageing	f_age	$\pm 3 \times 10^{-6}$	+25 $\pm$ 3 $^{\circ}$ C, First Year
Operating Temperature	T_use	-20 $^{\circ}$ C to +60 $^{\circ}$ C	
Storage Temperature	T_stg	-30 $^{\circ}$ C to +70 $^{\circ}$ C	Piece part basis

### DIMENSIONS

VT-120-F

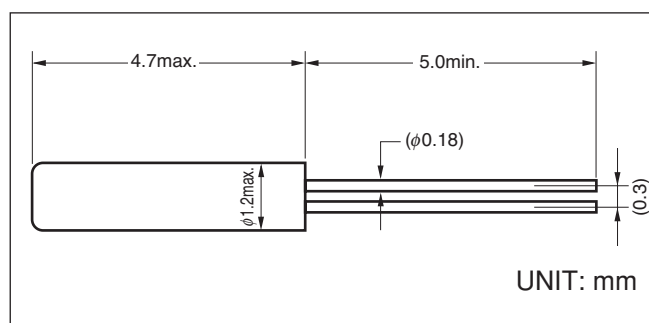

# Quartz Crystal Unit Handling Precautions

## MOUNTING PRECAUTIONS

### Lead Type Crystal Units

#### •Structure

Tubular crystal units (VT, VTC) are hermetically sealed using glass (see Figures 1 and 2).

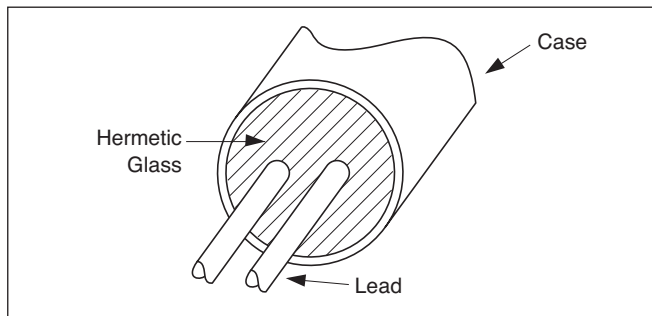

Figure 1

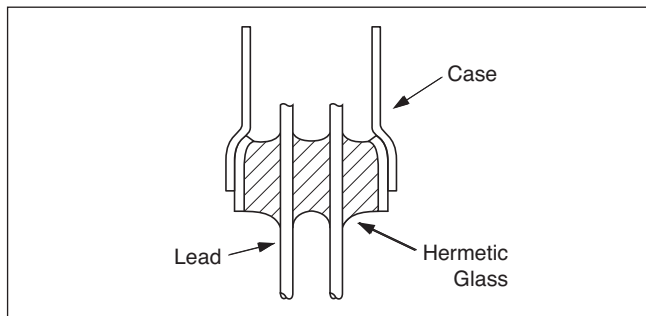

Figure 2

#### •Unbending the lead

- (1) DO NOT pull the lead excessively if unbending a lead or removing a crystal unit. The excessive force may crack the glass and reduce the degree of vacuum. This may eventually result in deterioration of the characteristics and may also break the crystal chip (see Figure 3).
- (2) Unbend the lead by pressing on the bent part from both the upper and lower sides with fixing the bottom of lead tightly. (see Figure 4).

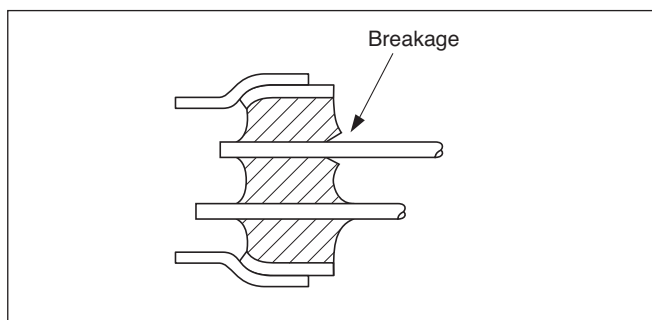

Figure 3

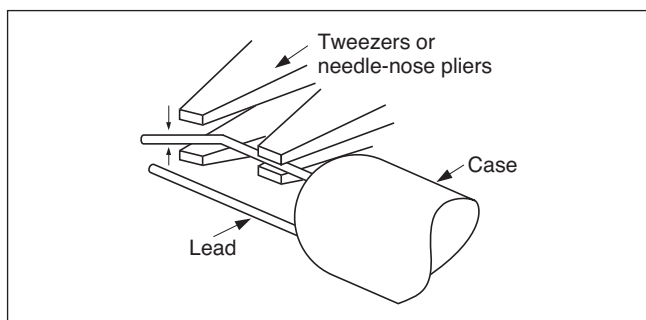

Figure 4

#### •Bending the lead

- (1) Bend the lead so that the lead will remain straight for more than 0.5mm from the case when soldering a crystal unit after bending. If not, the glass may be cracked (see Figures 5 and 6).
- (2) Always leave a length greater than the case diameter when bending a lead after soldering (see Figure 7).

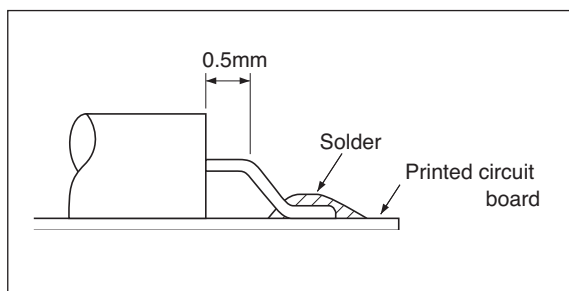

Figure 5

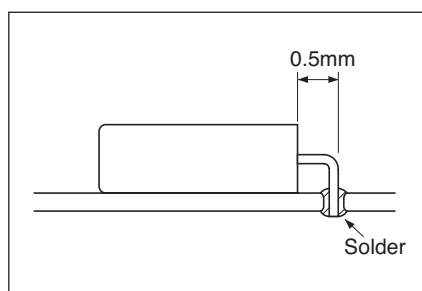

Figure 6

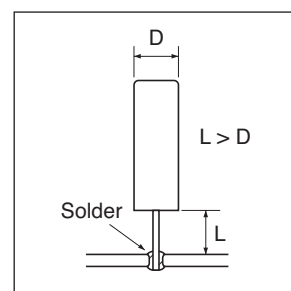

Figure 7

Soldering directly to the case will reduce the degree of vacuum and may result in deterioration of the characteristics and may break the crystal chip.

Make the length from the case to the printed circuit board (L) longer than the case diameter (D) so that the lead wire will not be pulled in case the crystal unit falls over.

#### •Soldering

The soldering position has to be at the lead wire more than 1.0mm away from the glass seal.

A long period of time of heating at high temperature may result in deterioration of the characteristics and may break the crystal unit.

If crystal unit is unavoidably heated, heat the lead part at 300°C or lower for 5 seconds or less and please make sure to keep the case below 150°C.

# Quartz Crystal Unit Handling Precautions

## SMD Type Quartz Crystal Units

### •Soldering

(1) An example of the reflow temperature profile is shown as follows (see Figure 8).

### Example of SMD product soldering conditions

(260°C peak: Lead-free products)

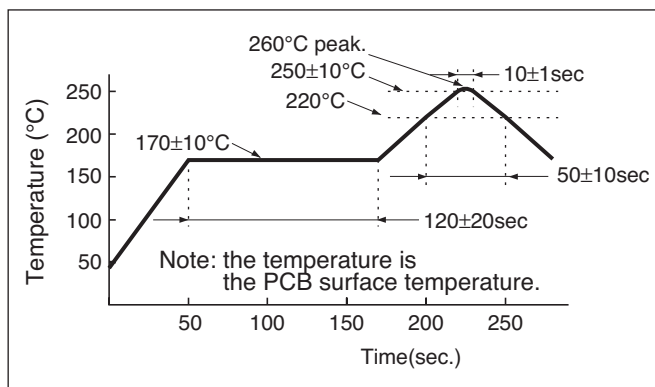

Figure 8

## CLEANING

Since a small, thin crystal chip is used for tuning fork crystal units and the frequency approximates that of an ultrasonic cleaner, the crystal chip may break easily. Therefore, DO NOT perform ultrasonic cleaning.

## MECHANICAL SHOCK

- (1) Quartz crystal units are designed to withstand a drop from 75cm onto a hard wooden board at least 3 times. However, their crystal chips may break depending on the conditions when they are dropped. Ensure that the crystal unit functions normally before use if the crystal units have been dropped or subjected to an excessive mechanical shock.
- (2) Unlike chip parts such as resistors, and capacitors, the SMD crystal unit has a crystal chip which is hermetically sealed inside. Therefore, check the influence of shock during automatic mounting or influence of deposition of case to the board by ultrasonic vibration before use.
- (3) Avoid mounting crystal unit to the board with mechanical vibration source including ultrasonic vibration source. If the crystal unit is unavoidably mounted to the same board with mechanical vibration source, ensure that the crystal unit functions normally.

# Oscillation Circuit Design Precautions

## DRIVE LEVEL (DL)

The drive level of a crystal unit is shown by the level of the operating power or the current consumption (see Figures 9, 10, and 11).

Operating the crystal unit at an excessive power level will result in the degradation of its characteristics, which may cause frequency instability or physical failure of the crystal chip.

Design your circuit within absolute maximum drive level.

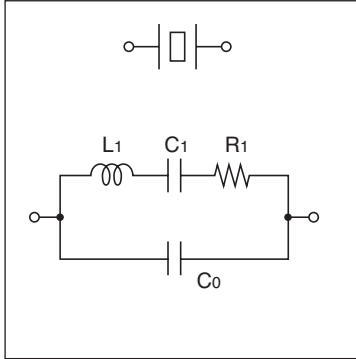

Figure 9

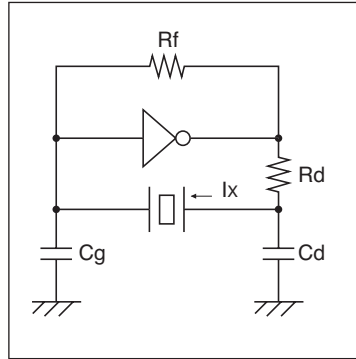

Figure 10

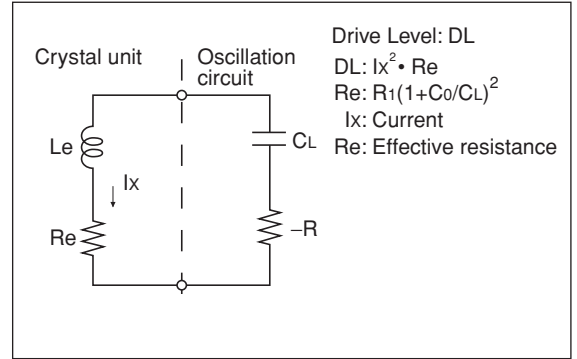

Figure 11

## OSCILLATION FREQUENCY AND LOAD CAPACITANCE (CL)

The load capacitance ( $C_L$ ) is a parameter for determining the frequency of the oscillation circuit. The  $C_L$  is represented by an effective equivalent capacitance that is loaded from the oscillation circuit to both ends of the crystal unit (see Figure 12).

The oscillation frequency varies depending upon the load capacitance of the oscillation circuit. In order to obtain the desirable frequency accuracy, matching between the load capacitances of the oscillation circuit and the crystal unit is required. For the use of the crystal unit, match the load capacitances of the oscillation circuit with the load capacitances of the crystal unit.

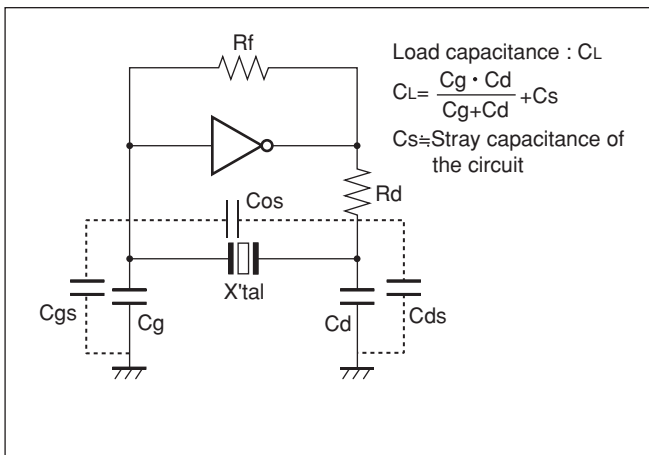

Figure 12

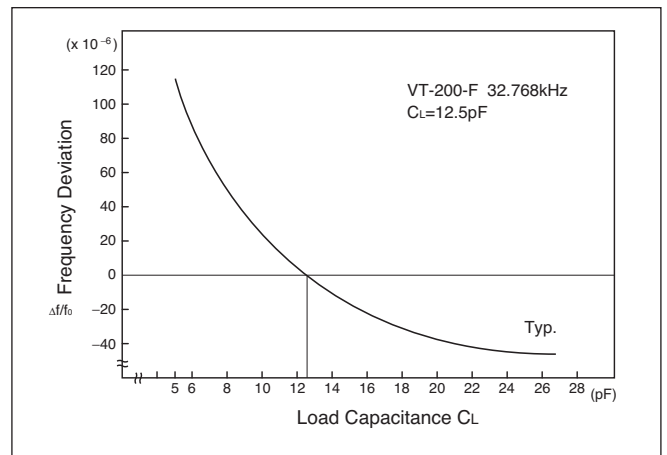

Figure 13

## OSCILLATION ALLOWANCE

To ensure stable oscillation, the negative resistance of the circuit should be significantly larger than the equivalent series resistance (the oscillation allowance is large). Ensure that the oscillation allowance is at least five times as large as the equivalent series resistance.

### Oscillation Allowance Evaluation Method

Add resistor “Rx” to the crystal unit in series and ensure that the oscillation starts or stops. The approximate negative resistance of the circuit is the value obtained by adding the effective resistance “Re” to the maximum resistance “Rx” when the oscillation starts or stops after gradually making Rx value larger.

### Negative resistance $|-R| = R_x + R_e$

$|-R|$  is a value at least five times as large as the maximum equivalent series resistance ( $R_1$  max.) of the crystal unit.

\*Re is the effective resistance value during oscillation.

$$R_e = R_1 \left(1 + \frac{C_0}{C_L}\right)^2$$

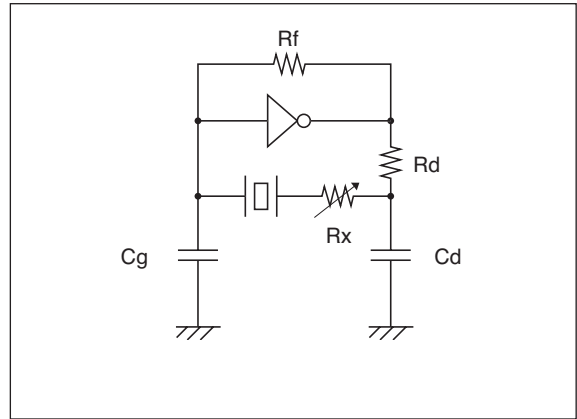
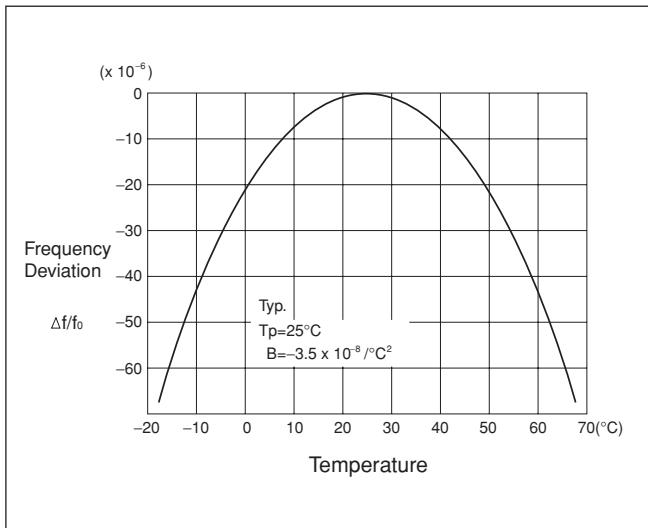

Figure 14

## FREQUENCY-TEMPERATURE CURVE



### Frequency Temperature Characteristics

Frequency temperature characteristics of tuning fork crystals is shown by negative quadratic curve which has a peak at 25°C as per left graph.

Please make sure to consider the temperature range and frequency accuracy you need since magnitude of frequency variation becomes larger and larger as the temperature range becomes wider.

[Approximation formula of frequency temperature characteristics]

$$f_{\text{tem}} = B (T - T_i)^2$$

- B : Parabolic coefficient
- T : Given temperature
- T<sub>i</sub> : Turnover temperature

# Packing

The following is the standard packing.

## LEAD TYPE PRODUCTS

After products are inserted in polyethylene bags, the bags are placed in boxes for shipping.

Product name	Quantity per lot	Quantity per bag		Quantity per box	
VT-120-F	10,000 pcs.	1,000 pcs.		10 bags	
VT-150-F	10,000 pcs.	500 pcs.	5,000 pcs.	20 bags	2 bags
VT-200-FL / VT-200-F / VTC-200-F	10,000 pcs.	500 pcs.		20 bags	

## SMD PRODUCTS

Product name	SSP-T7-FL / SSP-T7-F / SC-32S / SC-20S
Quantity per reel	3,000 pcs.

## TAPE AND REEL CONFIGURATION

•Reel configuration (Conforms with EIAJ ET-7200B)

SSP-T7-FL / SSP-T7-F

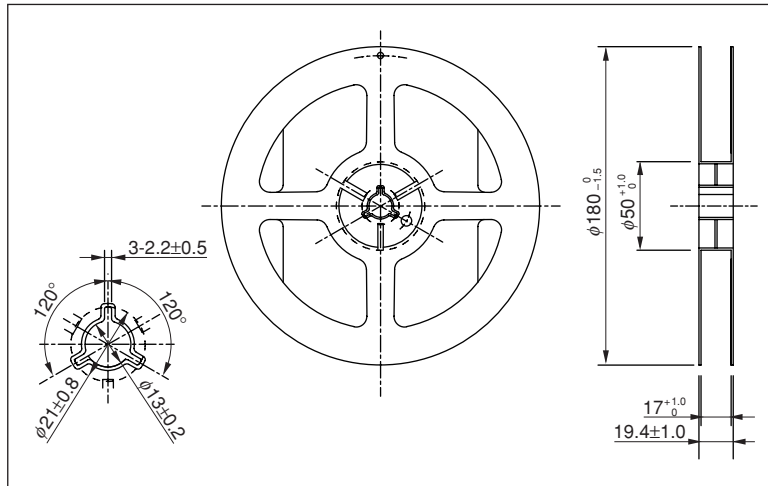

	SSP-T7-FL / SSP-T7-F
T	17.0
t	1.2

UNIT : mm

SC-32S

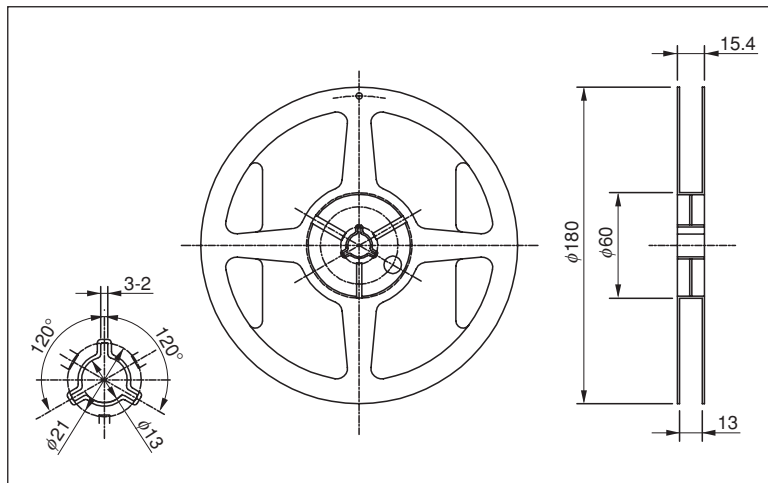

	SC-32S
T	15.4
t	1.2

UNIT : mm

SC-20S

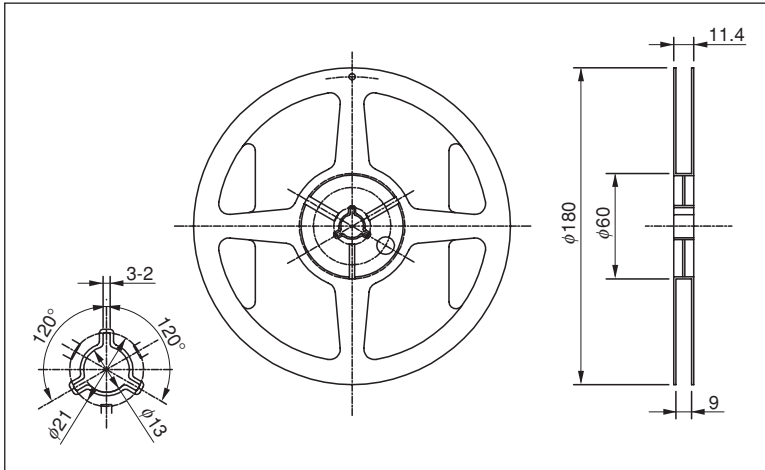

SC-20S	
T	11.4
t	1.2

UNIT : mm

• Emboss tape configuration

SSP-T7-FL / SSP-T7-F

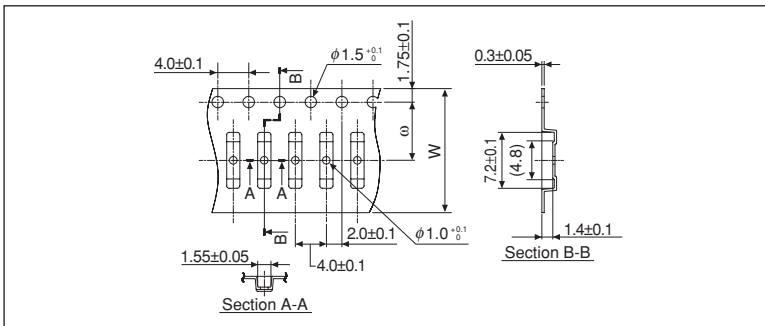

SSP-T7-FL / SSP-T7-F	
$\omega$	7.5
W	16.0

UNIT : mm

SC-32S

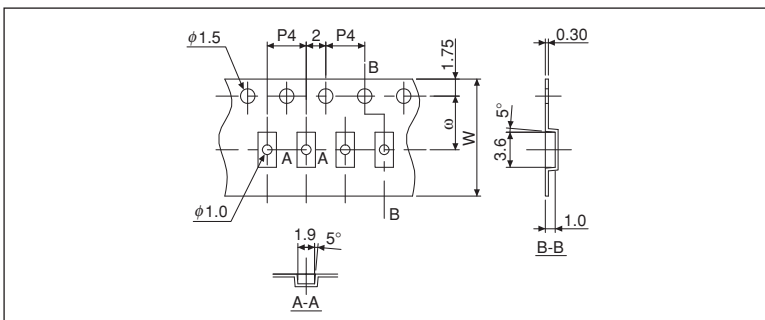

SC-32S	
$\omega$	5.5
W	12.0

UNIT : mm

SC-20S

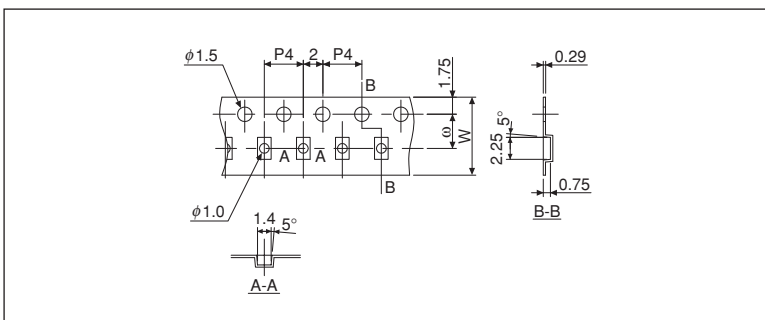

SC-20S	
$\omega$	3.5
W	8.0

UNIT : mm

**Remarks** Precautions for handling reels

- (1) Store at normal temperature and normal humidity (ref. to standard conditions of JIS Z-8703 laboratory). Avoid storing for a long time and mount the crystal units immediately after unpacked.  
[Normal temperature: +15 to 35°C Normal humidity: 25 to 85%RH]
- (2) Handle outside boxes and reels with care.  
Tapes and reels may be deformed by external pressure.



## SII GROUP ENVIRONMENTAL CONCEPT:

The SII Group will continue to harmonize its corporate activities with the global environment, designate the “Three Green” concept consisting of Green Process, Green Products and Green Life as our basic concept, promote and conduct environmental activities, and contribute to the establishment of a sustainable society that can coexist with nature.

### Environmental Actions taken by Quartz Crystal Division

#### 1. Manufacturing an Environmentally Friendly Product

- **RoHS Compliance<sup>\*1</sup> and other nations’ directive**

(including REACH: Registration, Evaluation, Authorization and restriction of Chemicals)

Before adopting new materials or processes, we make sure the material or process is not using any prohibited or restricted materials including RoHS designation. (The RoHS Directive has some exemptions, and some materials may follow these exemptions.)

\*1 The RoHS Directive stands for: [The Restriction of the use of certain Hazardous Substances in Electrical and Electronic Equipment]

- **Halogen free**

Incinerating Plastics with halogen elements (which also include bromine or chlorine) produce poisonous gases (dioxin.)

We have addressed the demand for Halogen free products.

Our Quartz Crystal Units are Halogen free and eco-friendly products.

- **Compliant with SII Green Product Label**

To raise public awareness of our eco-friendly products, SII introduced the SII Green Product Label System.

All the Quartz Crystal Units satisfy certain criteria and are certified as SII Green Products.



This mark means that the product complies with SII's own environmental standards.

#### 2. Save Energy and Contribute to Reducing Global Warming

- **Energy Saving in Manufacturing Process**

Promote measures for more efficient operation of air conditioning equipment, etc. to reduce CO<sub>2</sub> emissions.

#### 3. Resource Saving

- We promote 3R Activities (Reduce, Reuse and Recycle) of materials used in manufacturing processes and maintain zero emissions.

We also promote resource saving, such as reducing the amount of water used in processing as well as the reduction of industrial waste and chemicals.

#### 4. Green Purchase

- We promote “Green Purchase” along with “Green Purchase Guidelines”. These are two innovative programs established by SII Group.

#### 5. Green Life

- Our manufacturing site is located close to Ohirasan Natural Park. Accordingly we promote planting trees at our site and coordinate and participate in cleanup activities of local rivers and parks.

**IMPORTANT**

1. The information herein is subject to change without notice.
2. Neither reproduction, duplication nor unauthorized use of this catalog in whole or part is allowed without the prior written approval of Seiko Instruments Inc.
3. The colors of the products reproduced herein ("Products") may be different from the actual colors. Check colors on actual products before using the Products.
4. Circuits and respective application methods described herein are for reference only. Seiko Instruments Inc. shall not be liable for any damages or losses resulting from any claim by third parties that any Products or application methods described herein infringe any right intellectual

property right. All intellectual property rights with respect to the Products belong exclusively to Seiko Instruments Inc.

Seiko Instruments Inc. does not grant users of the Products any right or license to the Products hereunder.

5. When Products include Strategic Products (or Services) stipulated in the Foreign Exchange and Trade Control Law, they shall not be exported without permission of governmental authorities.
6. The Products are designed for consumer equipment and cannot be used as part of any device or equipment which influences the human body or requires a significantly high reliability, such as physical exercise equipment, medical equipment, disaster prevention equipment, gas related equipment, vehicles, aircraft and equipment mounted on vehicles.





The Quartz Crystal Division of Seiko Instruments Inc. who manufactures the products described in this catalog holds the ISO 9001 quality management system certificate, and the ISO 14001 environmental management systems certificate.



www.sii-crystal.com

**Seiko Instruments Inc.**  
 Quartz Crystal Sales Department  
 1-8, Nakase, Mihamaku, Chiba-shi, Chiba 261-8507, Japan  
 Telephone:+81-43-211-1214 Facsimile:+81-43-211-8030  
 Email:component@sii.co.jp

<Manufacture>  
**SII Crystal Technology Inc.**  
 1110, Hirai-cho, Tochigi-shi, Tochigi 328-0054, Japan

### Asia

**Seiko Instruments (H.K.) Ltd.**  
 4-5/F, Wyler Centre 2, 200 Tai Lin Pai Rd.,  
 Kwai Chung, N.T., Kowloon, Hong Kong  
 Telephone:+852-2421-8611  
 Facsimile:+852-2480-5479  
 E-mail:sales@sih.com.hk  
 http://www.sih.com.hk

**Shenzhen Office**  
 Room 2212-15, Office Tower, Shun Hing Square,  
 Di Wang Commercial Centre,  
 5002 Shen Nan Dong Rd.,  
 Shenzhen 518008, China  
 Telephone:+86-755-8246-2680  
 Facsimile:+86-755-8246-5140

**Seiko Instruments (Shanghai) Inc.**  
 Room 2902, 29th Floor, Shanghai Plaza,  
 138 Mid Huaihai Rd.,  
 Shanghai 200021, China  
 Telephone:+86-21-6375-6611  
 Facsimile:+86-21-6375-6727

**Seiko Instruments Taiwan Inc.**  
 12F, No.101, Sec.2, Nanking E.Rd.,  
 Taipei 104, Taiwan, R.O.C.  
 Telephone:+886-2-2563-5001  
 Facsimile:+886-2-2563-5580  
 E-mail:public@sii.co.jp  
 http://www.sii.com.tw

**Seiko Instruments Korea Inc.**  
 #507, 508, Korea City Air Terminal Bldg,  
 159-6, Samsung-dong, Gangnam-gu,  
 Seoul, 135-728 Korea  
 Telephone:+82-2-565-8006  
 Facsimile:+82-2-565-8306  
 http://www.sii.co.kr

### Europe

**Seiko Instruments GmbH**  
 Siemensstrasse 9  
 D-63263 Neu Isenburg, Germany  
 Telephone:+49-6102-297-0  
 Facsimile:+49-6102-297-50100  
 Email:info@seiko-instruments.de  
 http://www.seiko-instruments.de

### North/Central/South America

**Seiko Instruments U.S.A., Inc.**  
 21221 S. Western Ave., Suite 250,  
 Torrance, CA 90505, U.S.A.  
 Telephone:+1-310-517-7771  
 Facsimile:+1-310-517-7792  
 Email:info@siu-la.com  
 http://www.sii-crystal.com

(Specifications are subject to change without notice.)

Contact us

Released in July 2013



Printed on recycled paper

Copyright©2013 Seiko Instruments Inc. All Right Reserved.

No.QTC2003EJ-01C1307